



# M28W160BT M28W160BB

16 Mbit (1Mb x16, Boot Block)  
3V Supply Flash Memory

## FEATURES SUMMARY

- SUPPLY VOLTAGE
  - $V_{DD}$  = 2.7V to 3.6V Core Power Supply
  - $V_{DDQ}$  = 1.65V to 3.6V for Input/Output
  - $V_{PP}$  = 12V for fast Program (optional)
- ACCESS TIME: 70, 85, 90, 100ns
- PROGRAMMING TIME
  - 10 $\mu$ s typical
  - Double Word Programming Option
- COMMON FLASH INTERFACE
  - 64 bit Security Code
- MEMORY BLOCKS
  - Parameter Blocks (Top or Bottom location)
  - Main Blocks
- BLOCK PROTECTION on TWO PARAMETER BLOCKS
  - $\overline{WP}$  for Block Protection
- AUTOMATIC STAND-BY MODE
- PROGRAM and ERASE SUSPEND
- 100,000 PROGRAM/ERASE CYCLES per BLOCK
- ELECTRONIC SIGNATURE
  - Manufacturer Code: 20h
  - Top Device Code, M28W160BT: 90h
  - Bottom Device Code, M28W160BB: 91h

Figure 1. Packages

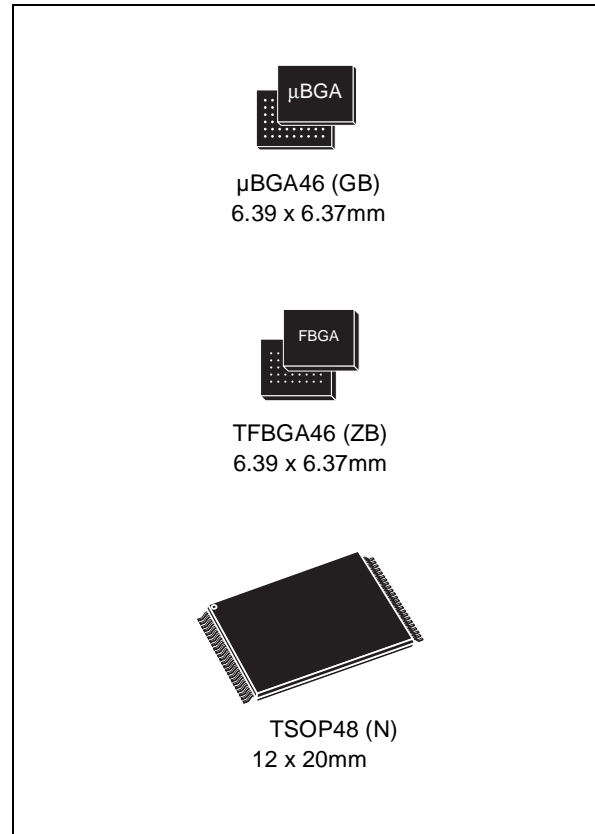

**TABLE OF CONTENTS**

**SUMMARY DESCRIPTION . . . . . 5**

- Figure 2. Logic Diagram . . . . . 5
- Table 1. Signal Names . . . . . 5
- Figure 3. TSOP Connections. . . . . 6
- Figure 4.  $\mu$ BGA Connections (Top view through package). . . . . 7
- Figure 5. TFBGA Connections (Top view through package). . . . . 8
- Figure 6. Block Addresses. . . . . 9

**SIGNAL DESCRIPTIONS . . . . . 10**

- Address Inputs (A0-A19). . . . . 10
- Data Input/Output (DQ0-DQ15). . . . . 10
- Chip Enable (E). . . . . 10
- Output Enable (G). . . . . 10
- Write Enable (W). . . . . 10
- Write Protect (WP). . . . . 10
- Reset (RP). . . . . 10
- V<sub>DD</sub> Supply Voltage. . . . . 10
- V<sub>DDQ</sub> Supply Voltage. . . . . 10
- V<sub>PP</sub> Program Supply Voltage . . . . . 10
- V<sub>SS</sub> Ground. . . . . 10

**BUS OPERATIONS. . . . . 11**

- Read. . . . . 11
- Write. . . . . 11
- Output Disable. . . . . 11
- Standby. . . . . 11
- Automatic Standby. . . . . 11
- Reset. . . . . 11
- Table 2. Bus Operations . . . . . 11

**COMMAND INTERFACE . . . . . 12**

- Read Memory Array command . . . . . 12
- Read Status Register Command. . . . . 12
- Read Electronic Signature Command . . . . . 12
- Read CFI Query Command. . . . . 12
- Block Erase Command . . . . . 12
- Program Command . . . . . 12
- Double Word Program Command . . . . . 13
- Clear Status Register Command. . . . . 13
- Program/Erase Suspend Command . . . . . 13
- Program/Erase Resume Command . . . . . 13
- Block Protection. . . . . 13
- Table 3. Commands . . . . . 14
- Table 4. Read Electronic Signature. . . . . 14

Table 5. Memory Blocks Protection Truth Table . . . . .	14
Table 6. Program, Erase Times and Program/Erase Endurance Cycles . . . . .	15
<b>STATUS REGISTER . . . . .</b>	<b>16</b>
Program/Erase Controller Status (Bit 7) . . . . .	16
Erase Suspend Status (Bit 6) . . . . .	16
Erase Status (Bit 5) . . . . .	16
Program Status (Bit 4) . . . . .	16
V <sub>PP</sub> Status (Bit 3) . . . . .	16
Program Suspend Status (Bit 2) . . . . .	16
Block Protection Status (Bit 1) . . . . .	17
Reserved (Bit 0) . . . . .	17
Table 7. Status Register Bits . . . . .	17
<b>MAXIMUM RATING . . . . .</b>	<b>18</b>
Table 8. Absolute Maximum Ratings . . . . .	18
<b>DC and AC PARAMETERS . . . . .</b>	<b>19</b>
Table 9. Operating and AC Measurement Conditions . . . . .	19
Figure 7. AC Measurement I/O Waveform . . . . .	19
Figure 8. AC Measurement Load Circuit . . . . .	19
Table 10. Device Capacitance . . . . .	19
Table 11. DC Characteristics . . . . .	20
Figure 9. Read Mode AC Waveforms . . . . .	21
Table 12. Read AC Characteristics . . . . .	21
Figure 10. Write AC Waveforms, Write Enable Controlled . . . . .	22
Table 13. Write AC Characteristics, Write Enable Controlled . . . . .	23
Figure 11. Write AC Waveforms, Chip Enable Controlled . . . . .	24
Table 14. Write AC Characteristics, Chip Enable Controlled . . . . .	25
Figure 12. Power-Up and Reset AC Waveforms . . . . .	26
Table 15. Power-Up and Reset AC Characteristics . . . . .	26
<b>PACKAGE MECHANICAL . . . . .</b>	<b>27</b>
Figure 13. TSOP48 - 48 lead Plastic Thin Small Outline, 12 x 20mm, Package Outline . . . . .	27
Table 16. TSOP48 - 48 lead Plastic Thin Small Outline, 12 x 20mm, Package Mechanical Data . . . . .	27
Figure 14. $\mu$ BGA46 6.39x6.37mm - 8 x 6 ball array, 0.75 mm pitch, Bottom View Package Outline . . . . .	28
Table 17. $\mu$ BGA46 6.39x6.37mm - 8 x 6 ball array, 0.75 mm pitch, Package Mechanical Data . . . . .	28
Figure 15. $\mu$ BGA46 Daisy Chain - Package Connections (Top view through package) . . . . .	29
Figure 16. $\mu$ BGA46 Daisy Chain - PCB Connections proposal (Top view through package) . . . . .	29
Figure 17. TFBGA46 6.39x6.37mm - 8x6 ball array, 0.75mm pitch, Bottom View Package Outline . . . . .	30
Table 18. TFBGA46 6.39x6.37mm - 8x6 ball array, 0.75mm pitch, Package Mechanical Data . . . . .	30
Figure 18. TFBGA46 Daisy Chain - Package Connections (Top view through package) . . . . .	31
Figure 19. TFBGA46 Daisy Chain - PCB Connections proposal (Top view through package) . . . . .	31
<b>PART NUMBERING . . . . .</b>	<b>32</b>

## M28W160BT, M28W160BB

---

Table 19. Ordering Information Scheme . . . . .	32
Table 20. Daisy Chain Ordering Scheme . . . . .	32
<b>REVISION HISTORY . . . . .</b>	<b>33</b>
Table 21. Document Revision History . . . . .	33
<b>APPENDIX A. BLOCK ADDRESS TABLES . . . . .</b>	<b>34</b>
Table 22. Top Boot Block Addresses, M28W160BT . . . . .	34
Table 23. Bottom Boot Block Addresses, M28W160BB . . . . .	34
<b>APPENDIX B. COMMON FLASH INTERFACE (CFI) . . . . .</b>	<b>35</b>
Table 24. Query Structure Overview . . . . .	35
Table 25. CFI Query Identification String . . . . .	35
Table 26. CFI Query System Interface Information . . . . .	36
Table 27. Device Geometry Definition . . . . .	37
Table 28. Primary Algorithm-Specific Extended Query Table . . . . .	38
Table 29. Security Code Area . . . . .	38
<b>APPENDIX C. FLOWCHARTS AND PSEUDO CODES . . . . .</b>	<b>39</b>
Figure 20. Program Flowchart and Pseudo Code . . . . .	39
Figure 21. Double Word Program Flowchart and Pseudo Code . . . . .	40
Figure 22. Program Suspend & Resume Flowchart and Pseudo Code . . . . .	41
Figure 23. Erase Flowchart and Pseudo Code . . . . .	42
Figure 24. Erase Suspend & Resume Flowchart and Pseudo Code . . . . .	43
<b>APPENDIX D. COMMAND INTERFACE AND PROGRAM/ERASE CONTROLLER STATE . . . . .</b>	<b>44</b>
Table 30. Write State Machine Current/Next. . . . .	44

**SUMMARY DESCRIPTION**

The M28W160B is a 16 Mbit (1 Mbit x 16) non-volatile Flash memory that can be erased electrically at the block level and programmed in-system on a Word-by-Word basis. These operations can be performed using a single low voltage (2.7 to 3.6V) supply. V<sub>DDQ</sub> allows to drive the I/O pin down to 1.65V. An optional 12V V<sub>PP</sub> power supply is provided to speed up customer programming.

The device features an asymmetrical blocked architecture. The M28W160B has an array of 39 blocks: 8 Parameter Blocks of 4 KWord and 31 Main Blocks of 32 KWord. M28W160BT has the Parameter Blocks at the top of the memory address space while the M28W160BB locates the Parameter Blocks starting from the bottom. The memory maps are shown in Figure 6, Block Addresses.

Parameter blocks 0 and 1 can be protected from accidental programming or erasure. Each block can be erased separately. Erase can be suspended in order to perform either read or program in any other block and then resumed. Program can be suspended to read data in any other block and then resumed. Each block can be programmed and erased over 100,000 cycles.

Program and Erase commands are written to the Command Interface of the memory. An on-chip Program/Erase Controller takes care of the timings necessary for program and erase operations. The end of a program or erase operation can be detected and any error conditions identified. The command set required to control the memory is consistent with JEDEC standards.

The memory is offered in TSOP48 (10 X 20mm), μBGA46 (6.39 x 6.37mm, 0.75mm pitch) and TFBGA46 (6.39 x 6.37mm, 0.75mm pitch) packages and is supplied with all the bits erased (set to '1').

**Figure 2. Logic Diagram**

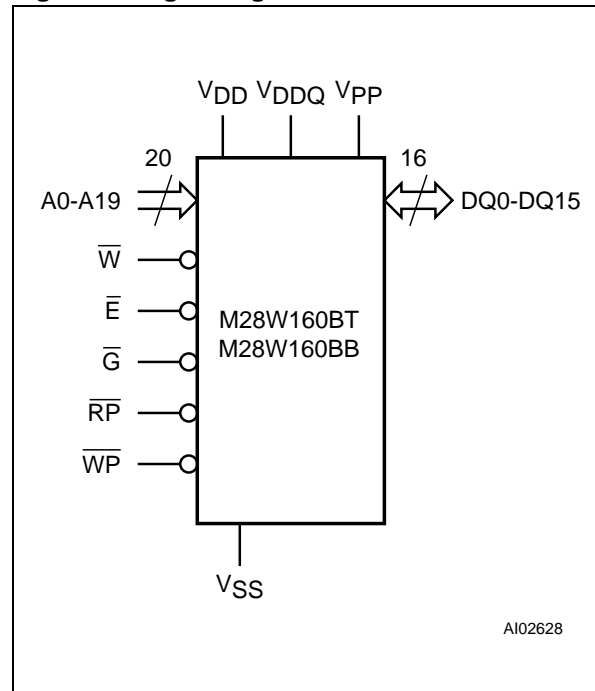

**Table 1. Signal Names**

A0-A19	Address Inputs
DQ0-DQ15	Data Input/Output
$\bar{E}$	Chip Enable
$\bar{G}$	Output Enable
$\bar{W}$	Write Enable
$\overline{RP}$	Reset
$\overline{WP}$	Write Protect
V <sub>DD</sub>	Core Power Supply
V <sub>DDQ</sub>	Power Supply for Input/Output
V <sub>PP</sub>	Optional Supply Voltage for Fast Program & Erase
V <sub>SS</sub>	Ground

**M28W160BT, M28W160BB**

**Figure 3. TSOP Connections**

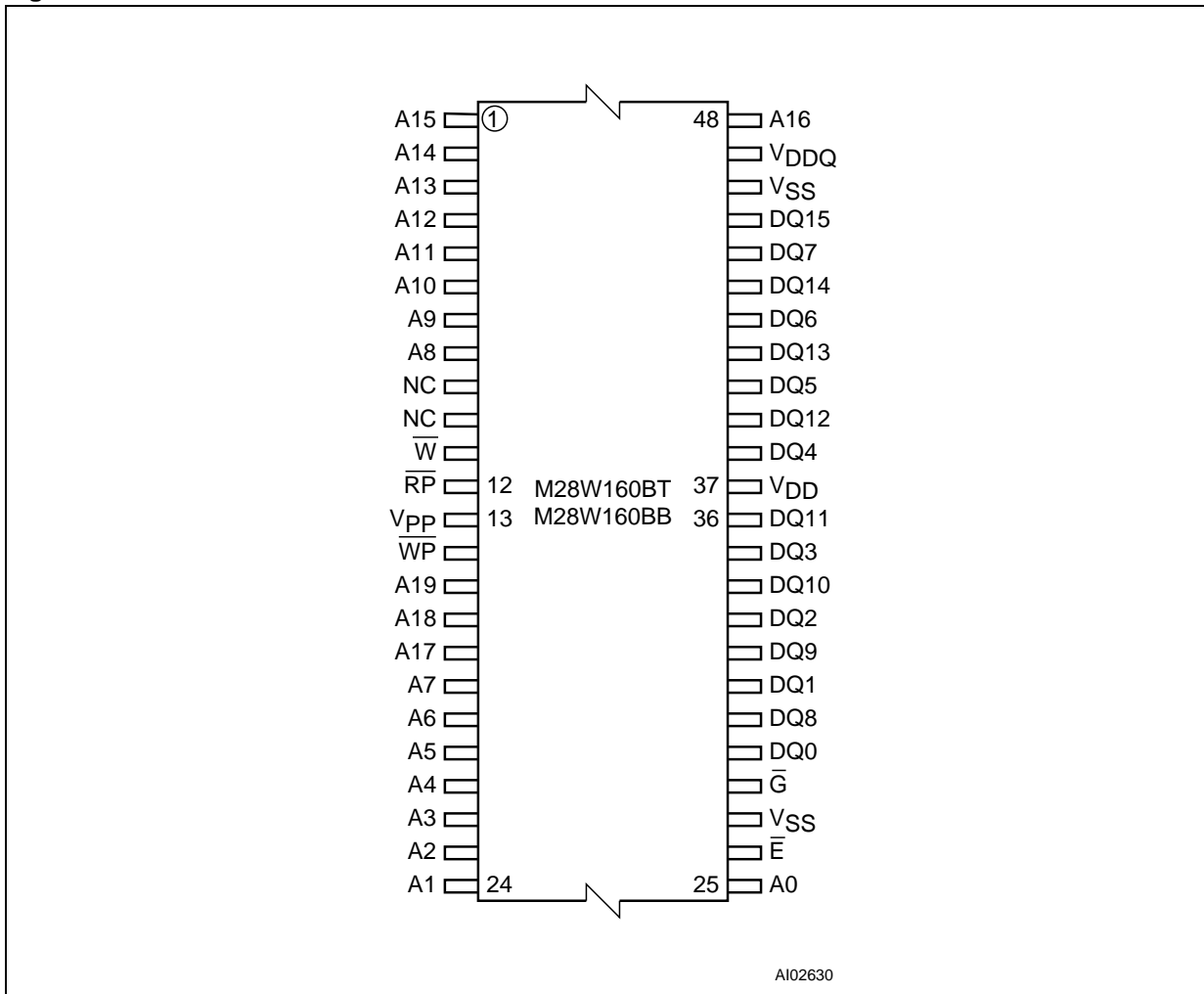

Figure 4.  $\mu$ BGA Connections (Top view through package)

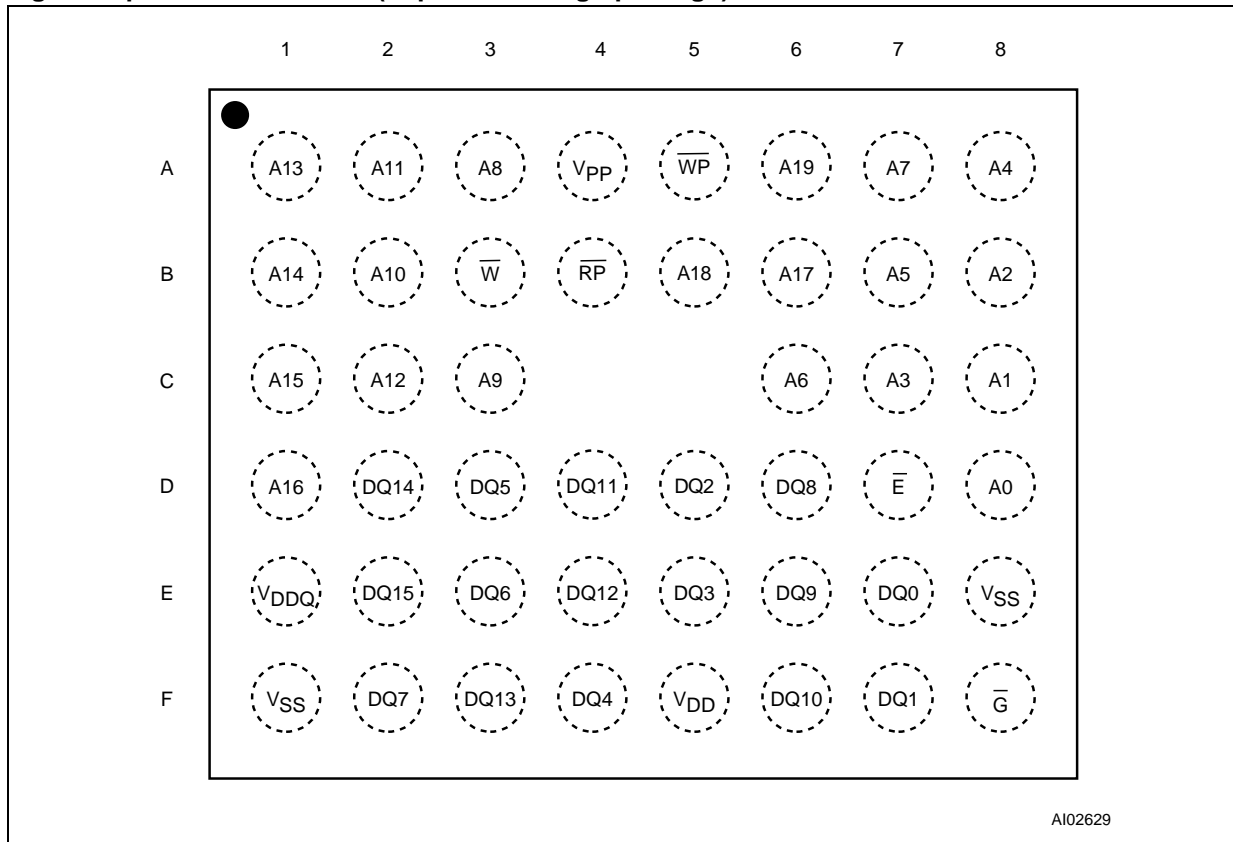

Figure 5. TFBGA Connections (Top view through package)

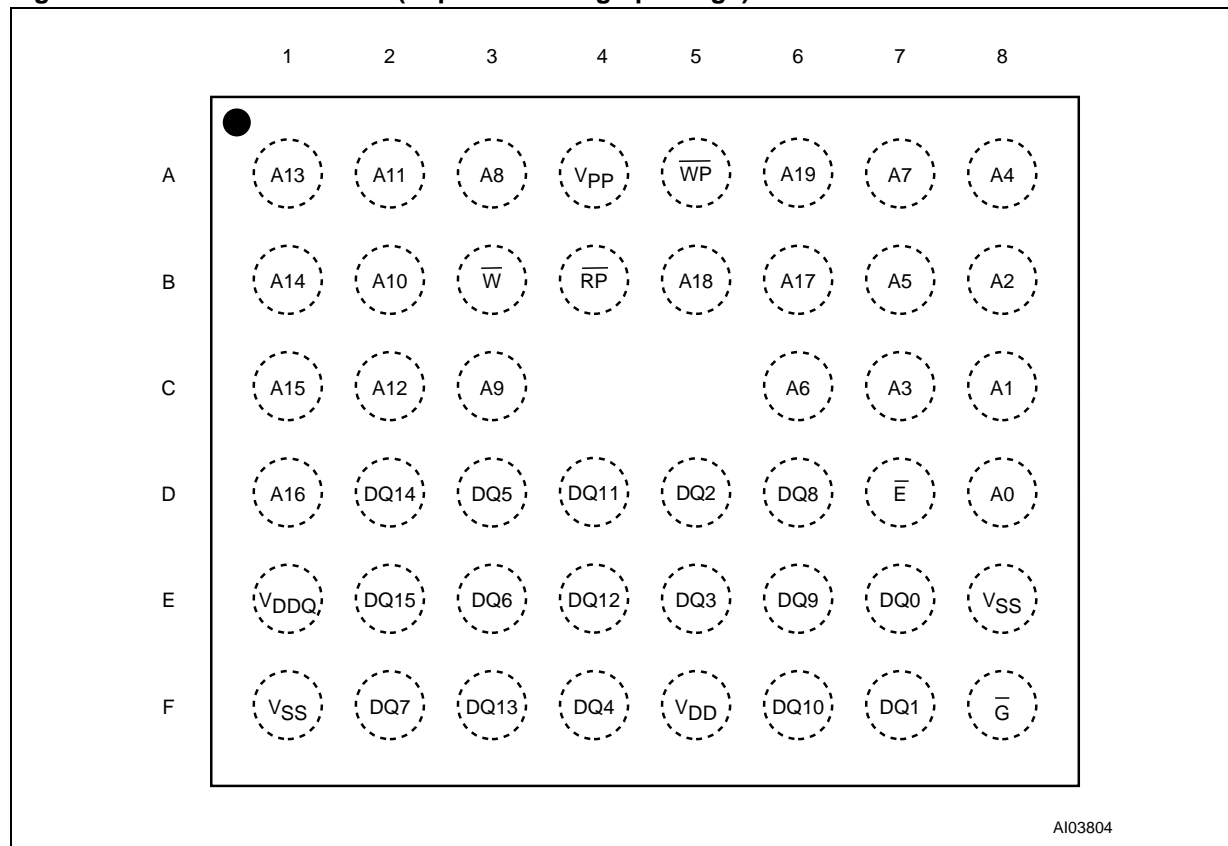
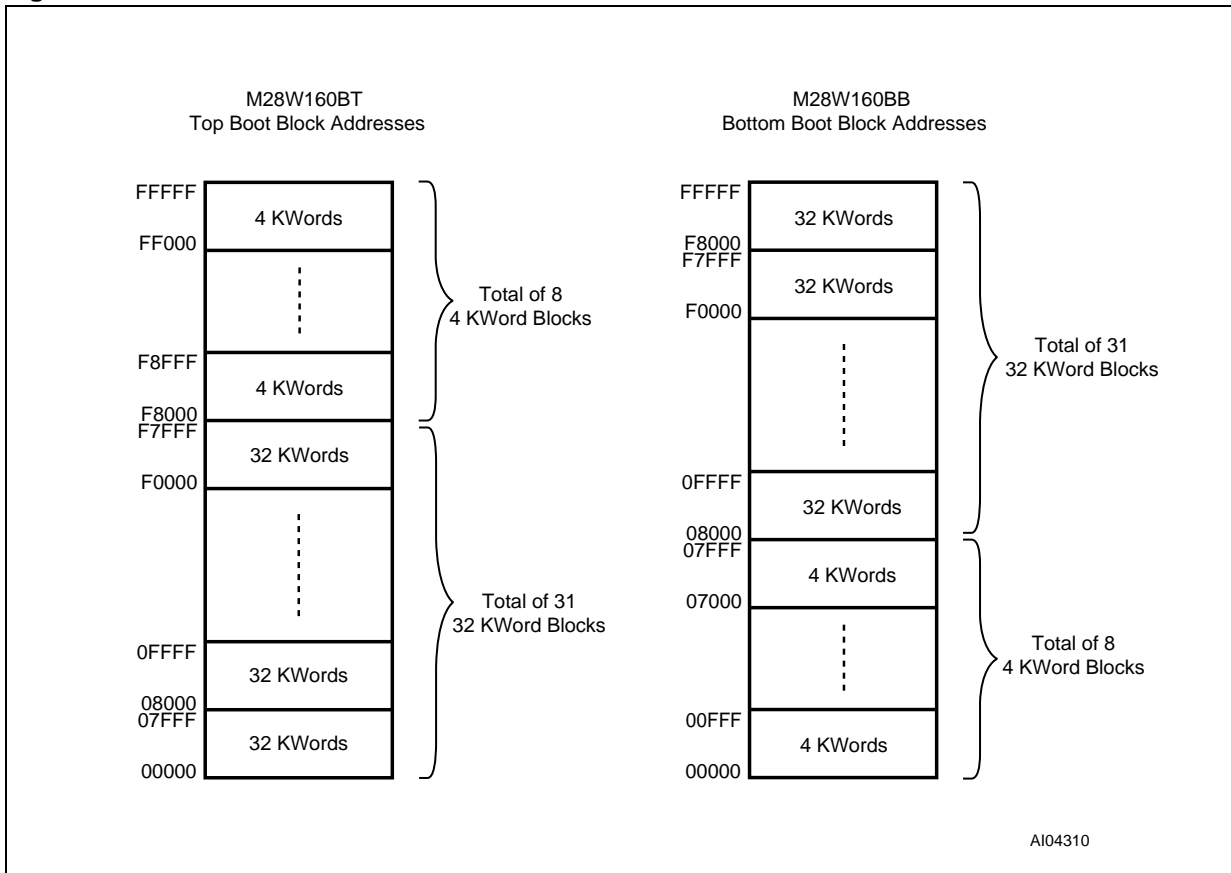



Figure 6. Block Addresses



Note: Also see Appendix A, Tables 22 and 23 for a full listing of the Block Addresses.

**SIGNAL DESCRIPTIONS**

See Figure 2 Logic Diagram and Table 1, Signal Names, for a brief overview of the signals connected to this device.

**Address Inputs (A0-A19).** The Address Inputs select the cells in the memory array to access during Bus Read operations. During Bus Write operations they control the commands sent to the Command Interface of the internal state machine.

**Data Input/Output (DQ0-DQ15).** The Data I/O outputs the data stored at the selected address during a Bus Read operation or inputs a command or data to be programmed during a Write Bus operation.

**Chip Enable ( $\overline{E}$ ).** The Chip Enable input activates the memory control logic, input buffers, decoders and sense amplifiers. When Chip Enable is at  $V_{IL}$  and Reset is at  $V_{IH}$  the device is in active mode. When Chip Enable is at  $V_{IH}$  the memory is deselected, the outputs are high impedance and the power consumption is reduced to the stand-by level.

**Output Enable ( $\overline{G}$ ).** The Output Enable controls data outputs during the Bus Read operation of the memory.

**Write Enable ( $\overline{W}$ ).** The Write Enable controls the Bus Write operation of the memory's Command Interface. The data and address inputs are latched on the rising edge of Chip Enable,  $\overline{E}$ , or Write Enable,  $\overline{W}$ , whichever occurs first.

**Write Protect ( $\overline{WP}$ ).** Write Protect is an input to protect or unprotect the two lockable parameter blocks. When Write Protect is at  $V_{IL}$ , the lockable blocks are protected and Program or Erase operations are not possible. When Write Protect is at  $V_{IH}$ , the lockable blocks are unprotected and can be programmed or erased (refer to Table 4, Memory Blocks Protection Truth).

**Reset (RP).** The Reset input provides a hardware reset of the memory. When Reset is at  $V_{IL}$ , the memory is in reset mode: the outputs are high impedance and the current consumption is mini-

mized. When Reset is at  $V_{IH}$ , the device is in normal operation. Exiting reset mode the device enters read array mode, but a negative transition of Chip Enable or a change of the address is required to ensure valid data outputs.

**$V_{DD}$  Supply Voltage.**  $V_{DD}$  provides the power supply to the internal core of the memory device. It is the main power supply for all operations (Read, Program and Erase).

**$V_{DDQ}$  Supply Voltage.**  $V_{DDQ}$  provides the power supply to the I/O pins and enables all Outputs to be powered independently from  $V_{DD}$ .  $V_{DDQ}$  can be tied to  $V_{DD}$  or can use a separate supply.

**$V_{PP}$  Program Supply Voltage.**  $V_{PP}$  is both a control input and a power supply pin. The two functions are selected by the voltage range applied to the pin. The Supply Voltage  $V_{DD}$  and the Program Supply Voltage  $V_{PP}$  can be applied in any order.

If  $V_{PP}$  is kept in a low voltage range (0V to 3.6V)  $V_{PP}$  is seen as a control input. In this case a voltage lower than  $V_{PPLK}$  gives an absolute protection against program or erase, while  $V_{PP} > V_{PP1}$  enables these functions (see Table 11, DC Characteristics for the relevant values).  $V_{PP}$  is only sampled at the beginning of a program or erase; a change in its value after the operation has started does not have any effect and program or erase operations continue.

If  $V_{PP}$  is in the range 11.4V to 12.6V it acts as a power supply pin. In this condition  $V_{PP}$  must be stable until the Program/Erase algorithm is completed (see Table 13 and 14).

**$V_{SS}$  Ground.**  $V_{SS}$  is the reference for all voltage measurements.

**Note:** Each device in a system should have  $V_{DD}$ ,  $V_{DDQ}$  and  $V_{PP}$  decoupled with a 0.1 $\mu$ F capacitor close to the pin. See Figure 8, AC Measurement Load Circuit. The PCB trace widths should be sufficient to carry the required  $V_{PP}$  Program and Erase currents.

## BUS OPERATIONS

There are six standard bus operations that control the device. These are Bus Read, Bus Write, Output Disable, Standby, Automatic Standby and Reset. See Table 2, Bus Operations, for a summary.

Typically glitches of less than 5ns on Chip Enable or Write Enable are ignored by the memory and do not affect bus operations.

**Read.** Read Bus operations are used to output the contents of the Memory Array, the Electronic Signature, the Status Register and the Common Flash Interface. Both Chip Enable and Output Enable must be at  $V_{IL}$  in order to perform a read operation. The Chip Enable input should be used to enable the device. Output Enable should be used to gate data onto the output. The data read depends on the previous command written to the memory (see Command Interface section). See Figure 9, Read Mode AC Waveforms, and Table 12, Read AC Characteristics, for details of when the output becomes valid.

Read mode is the default state of the device when exiting Reset or after power-up.

**Write.** Bus Write operations write Commands to the memory or latch Input Data to be programmed. A write operation is initiated when Chip Enable and Write Enable are at  $V_{IL}$  with Output Enable at  $V_{IH}$ . Commands, Input Data and Addresses are latched on the rising edge of Write Enable or Chip Enable, whichever occurs first.

See Figures 10 and 11, Write AC Waveforms, and Tables 13 and 14, Write AC Characteristics, for details of the timing requirements.

**Output Disable.** The data outputs are high impedance when the Output Enable is at  $V_{IH}$ .

**Standby.** Standby disables most of the internal circuitry allowing a substantial reduction of the current consumption. The memory is in stand-by when Chip Enable is at  $V_{IH}$  and the device is in read mode. The power consumption is reduced to the stand-by level and the outputs are set to high impedance, independently from the Output Enable or Write Enable inputs. If Chip Enable switches to  $V_{IH}$  during a program or erase operation, the device enters Standby mode when finished.

**Automatic Standby.** Automatic Standby provides a low power consumption state during Read mode. Following a read operation, the device enters Automatic Standby after 150ns of bus inactivity, even if Chip Enable is low,  $V_{IL}$ , and the supply current is reduced to  $I_{DD1}$ . The data Inputs/Outputs will still output data.

**Reset.** During Reset mode, when Output Enable is low,  $V_{IL}$ , the memory is deselected and the outputs are high impedance. The memory is in Reset mode when Reset is at  $V_{IL}$ . The power consumption is reduced to the Standby level, independently from the Chip Enable, Output Enable or Write Enable inputs. If Reset is pulled to  $V_{SS}$  during a Program or Erase, this operation is aborted and the memory content is no longer valid.

**Table 2. Bus Operations**

Operation	$\overline{E}$	$\overline{G}$	$\overline{W}$	$\overline{RP}$	$\overline{WP}$	$V_{PP}$	DQ0-DQ15
Read	$V_{IL}$	$V_{IL}$	$V_{IH}$	$V_{IH}$	X	Don't Care	Data Output
Write	$V_{IL}$	$V_{IH}$	$V_{IL}$	$V_{IH}$	X	$V_{DD}$ or $V_{PPH}$	Data Input
Output Disable	$V_{IL}$	$V_{IH}$	$V_{IH}$	$V_{IH}$	X	Don't Care	Hi-Z
Standby	$V_{IH}$	X	X	$V_{IH}$	X	Don't Care	Hi-Z
Reset	X	X	X	$V_{IL}$	X	Don't Care	Hi-Z

Note: X =  $V_{IL}$  or  $V_{IH}$ ,  $V_{PPH} = 12V \pm 5\%$ .

**COMMAND INTERFACE**

All Bus Write operations to the memory are interpreted by the Command Interface. Commands consist of one or more sequential Bus Write operations. An internal Program/Erase Controller handles all timings and verifies the correct execution of the Program and Erase commands. The Program/Erase Controller provides a Status Register whose output may be read at any time, to monitor the progress of an operation, or the Program/Erase states. See Appendix D, Table 30, Write State Machine Current/Next, for a summary of the Command Interface.

The Command Interface is reset to Read mode when power is first applied, when exiting from Reset or whenever  $V_{DD}$  is lower than  $V_{LKO}$ . Command sequences must be followed exactly. Any invalid combination of commands will reset the device to Read mode. Refer to Table 3, Commands, in conjunction with the text descriptions below.

**Read Memory Array command**

The Read command returns the memory to its Read mode. One Bus Write cycle is required to issue the Read Memory Array command and return the memory to Read mode. Subsequent read operations will read the addressed location and output the data. When a device Reset occurs, the memory defaults to Read mode.

**Read Status Register Command**

The Status Register indicates when a program or erase operation is complete and the success or failure of the operation itself. Issue a Read Status Register command to read the Status Register's contents. Subsequent Bus Read operations read the Status Register, at any address, until another command is issued. See Table 7, Status Register Bits, for details on the definitions of the bits.

The Read Status Register command may be issued at any time, even during a Program/Erase operation. Any Read attempt during a Program/Erase operation will automatically output the content of the Status Register.

**Read Electronic Signature Command**

The Read Electronic Signature command reads the Manufacturer and Device Codes.

The Read Electronic Signature command consists of one write cycle, a subsequent read will output the Manufacturer or the Device Code depending on the levels of A0. The Manufacturer Code is output when the address line A0 is at  $V_{IL}$ , the Device Code is output when A0 is at  $V_{IH}$ . Addresses A1-A7 must be kept to  $V_{IL}$ , other addresses are ignored. The codes are output on DQ0-DQ7 with DQ8-DQ15 at 00h. (see Table 4)

**Read CFI Query Command**

The Read Query Command is used to read data from the Common Flash Interface (CFI) Memory Area, allowing programming equipment or applications to automatically match their interface to the characteristics of the device.

One Bus Write cycle is required to issue the Read Query Command. Once the command is issued subsequent Bus Read operations read from the Common Flash Interface Memory Area. See Appendix B, Common Flash Interface, Tables 24, 25, 26, 27, 28 and 29 for details on the information contained in the Common Flash Interface memory area.

**Block Erase Command**

The Block Erase command can be used to erase a block. It sets all the bits within the selected block to '1'. All previous data in the block is lost. If the block is protected then the Erase operation will abort, the data in the block will not be changed and the Status Register will output the error.

Two Bus Write cycles are required to issue the command.

- The first bus cycle sets up the Erase command.
- The second latches the block address in the internal state machine and starts the Program/Erase Controller.

If the second bus cycle is not Write Erase Confirm (D0h), Status Register bits b4 and b5 are set and the command aborts.

Erase aborts if Reset turns to  $V_{IL}$ . As data integrity cannot be guaranteed when the Erase operation is aborted, the block must be erased again.

During Erase operations the memory will only accept the Read Status Register command and the Program/Erase Suspend command, all other commands will be ignored. Typical Erase times are given in Table 6, Program, Erase Times and Program/Erase Endurance Cycles.

See Appendix C, Figure 23, Erase Flowchart and Pseudo Code, for the flowchart for using the Erase command.

**Program Command**

The memory array can be programmed word-by-word. Two bus write cycles are required to issue the Program command.

- The first bus cycle sets up the Program command.
- The second latches the Address and the Data to be written and starts the Program/Erase Controller.

During Program operations the memory will only accept the Read Status Register command and the Program/Erase Suspend command. All other

commands will be ignored. Typical Program times are given in Table 6, Program, Erase Times and Program/Erase Endurance Cycles.

Programming aborts if Reset goes to  $V_{IL}$ . As data integrity cannot be guaranteed when the program operation is aborted, the block containing the memory location must be erased and reprogrammed.

See Appendix C, Figure 20, Program Flowchart and Pseudo Code, for the flowchart for using the Program command.

#### Double Word Program Command

This feature is offered to improve the programming throughput, writing a page of two adjacent words in parallel. The two words must differ only for the address A0. Programming should not be attempted when  $V_{PP}$  is not at  $V_{PPH}$ . The command can be executed if  $V_{PP}$  is below  $V_{PPH}$  but the result is not guaranteed.

Three bus write cycles are necessary to issue the Double Word Program command.

- The first bus cycle sets up the Double Word Program command.
- The second bus cycle latches the Address and the Data of the first word to be written.
- The third bus cycle latches the Address and the Data of the second word to be written and starts the Program/Erase Controller.

Read operations output the Status Register content after the programming has started. Programming aborts if Reset goes to  $V_{IL}$ . As data integrity cannot be guaranteed when the program operation is aborted, the block containing the memory location must be erased and reprogrammed.

See Appendix C, Figure 21, Double Word Program Flowchart and Pseudo Code, for the flowchart for using the Double Word Program command.

#### Clear Status Register Command

The Clear Status Register command can be used to reset bits 1, 3, 4 and 5 in the Status Register to '0'. One bus write cycle is required to issue the Clear Status Register command.

The bits in the Status Register do not automatically return to '0' when a new Program or Erase command is issued. The error bits in the Status Register should be cleared before attempting a new Program or Erase command.

#### Program/Erase Suspend Command

The Program/Erase Suspend command is used to pause a Program or Erase operation. One bus write cycle is required to issue the Program/Erase command and pause the Program/Erase controller.

During Program/Erase Suspend the Command Interface will accept the Program/Erase Resume, Read Array, Read Status Register, Read Electronic Signature and Read CFI Query commands. Additionally, if the suspend operation was Erase then the Program command will also be accepted. Only the blocks not being erased may be read or programmed correctly.

During a Program/Erase Suspend, the device can be placed in a pseudo-standby mode by taking Chip Enable to  $V_{IH}$ . Program/Erase is aborted if Reset turns to  $V_{IL}$ .

See Appendix C, Figure 22, Program Suspend & Resume Flowchart and Pseudo Code, and Figure 24, Erase Suspend & Resume Flowchart and Pseudo Code for flowcharts for using the Program/Erase Suspend command.

#### Program/Erase Resume Command

The Program/Erase Resume command can be used to restart the Program/Erase Controller after a Program/Erase Suspend operation has paused it. One Bus Write cycle is required to issue the command. Once the command is issued subsequent Bus Read operations read the Status Register.

See Appendix C, Figure 22, Program or Double Word Program Suspend & Resume Flowchart and Pseudo Code, and Figure 24, Erase Suspend & Resume Flowchart and Pseudo Code for flowcharts for using the Program/Erase Resume command.

#### Block Protection

Two parameter/lockable blocks (blocks #0 and #1) can be protected against Program or Erase operations. Unprotected blocks can be programmed or erased.

To protect the two lockable blocks set Write Protect to  $V_{IL}$ . When  $V_{PP}$  is below  $V_{PPLK}$  all blocks are protected. Any attempt to Program or Erase protected blocks will abort, the data in the block will not be changed and the Status Register outputs the error.

Table 5, Memory Blocks Protection Truth Table, defines the protection methods.

## M28W160BT, M28W160BB

**Table 3. Commands**

Commands	No. of Cycles	Bus Write Operations								
		1st Cycle			2nd Cycle			3rd Cycle		
		Bus Op.	Addr	Data	Bus Op.	Addr	Data	Bus Op.	Addr	Data
Read Memory Array	1+	Write	X	FFh	Read	Read Addr	Data			
Read Status Register	1+	Write	X	70h	Read	X	Status Register			
Read Electronic Signature	1+	Write	X	90h	Read	Signature Addr (2)	Signature			
Read CFI Query	1+	Write	X	98h	Read	CFI Addr	Query			
Erase	2	Write	X	20h	Write	Block Addr	D0h			
Program	2	Write	X	40h or 10h	Write	Addr	Data Input			
Double Word Program <sup>(3)</sup>	3	Write	X	30h	Write	Addr 1	Data Input	Write	Addr 2	Data Input
Clear Status Register	1	Write	X	50h						
Program/Erase Suspend	1	Write	X	B0h						
Program/Erase Resume	1	Write	X	D0h						

Note: 1. X = Don't Care.

2. A0=V<sub>IL</sub> outputs Manufacturer code, A0=V<sub>IH</sub> outputs Device code. Address A7-A1 must be V<sub>IL</sub>.

3. Addr 1 and Addr 2 must be consecutive Addresses differing only for A0.

**Table 4. Read Electronic Signature**

Code	Device	$\overline{E}$	$\overline{G}$	$\overline{W}$	A0	A1-A7	A8-A19	DQ0-DQ15
Manufact. Code		V <sub>IL</sub>	V <sub>IL</sub>	V <sub>IH</sub>	V <sub>IL</sub>	V <sub>IL</sub>	Don't Care	20h
Device Code	M28W160BT	V <sub>IL</sub>	V <sub>IL</sub>	V <sub>IH</sub>	V <sub>IH</sub>	V <sub>IL</sub>	Don't Care	90h
	M28W160BB	V <sub>IL</sub>	V <sub>IL</sub>	V <sub>IH</sub>	V <sub>IH</sub>	V <sub>IL</sub>	Don't Care	91h

Note:  $\overline{RP} = V_{IH}$ .

**Table 5. Memory Blocks Protection Truth Table**

V <sub>PP</sub> <sup>(1)</sup>	$\overline{RP}$	$\overline{WP}$ <sup>(1)</sup>	Lockable Blocks (blocks #0 and #1)	Other Blocks
X	V <sub>IL</sub>	X	Protected	Protected
V <sub>IL</sub>	V <sub>IH</sub>	X	Protected	Protected
V <sub>DD</sub> or V <sub>PPH</sub> <sup>(2)</sup>	V <sub>IH</sub>	V <sub>IL</sub>	Protected	Unprotected
V <sub>DD</sub> or V <sub>PPH</sub> <sup>(2)</sup>	V <sub>IH</sub>	V <sub>IH</sub>	Unprotected	Unprotected

Note: 1. X = Don't Care

2. V<sub>PP</sub> must also be greater than the Program Voltage Lock Out V<sub>PPLK</sub>.

Table 6. Program, Erase Times and Program/Erase Endurance Cycles

Parameter	Test Conditions	M28W160B			Unit
		Min	Typ	Max	
Word Program	$V_{PP} = V_{DD}$		10	200	$\mu\text{s}$
Double Word Program	$V_{PP} = 12V \pm 5\%$		10	200	$\mu\text{s}$
Main Block Program	$V_{PP} = 12V \pm 5\%$		0.16	5	s
	$V_{PP} = V_{DD}$		0.32	5	s
Parameter Block Program	$V_{PP} = 12V \pm 5\%$		0.02	4	s
	$V_{PP} = V_{DD}$		0.04	4	s
Main Block Erase	$V_{PP} = 12V \pm 5\%$		1	10	s
	$V_{PP} = V_{DD}$		1	10	s
Parameter Block Erase	$V_{PP} = 12V \pm 5\%$		0.8	10	s
	$V_{PP} = V_{DD}$		0.8	10	s
Program/Erase Cycles (per Block)		100,000			cycles

**STATUS REGISTER**

The Status Register provides information on the current or previous Program or Erase operation. The various bits convey information and errors on the operation. To read the Status register the Read Status Register command can be issued, refer to the Read Status Register Command section. To output the contents, the Status Register is latched on the falling edge of the Chip Enable or Output Enable signals, and can be read until Chip Enable or Output Enable returns to  $V_{IH}$ . Either Chip Enable or Output Enable must be toggled to update the latched data.

Bus Read operations from any address always read the Status Register during Program and Erase operations.

The bits in the Status Register are summarized in Table 7, Status Register Bits. Refer to Table 7 in conjunction with the following text descriptions.

**Program/Erase Controller Status (Bit 7).** The Program/Erase Controller Status bit indicates whether the Program/Erase Controller is active or inactive. When the Program/Erase Controller Status bit is Low (set to '0'), the Program/Erase Controller is active; when the bit is High (set to '1'), the Program/Erase Controller is inactive, and the device is ready to process a new command.

The Program/Erase Controller Status is Low immediately after a Program/Erase Suspend command is issued until the Program/Erase Controller pauses. After the Program/Erase Controller pauses the bit is High.

During Program, Erase, operations the Program/Erase Controller Status bit can be polled to find the end of the operation. Other bits in the Status Register should not be tested until the Program/Erase Controller completes the operation and the bit is High.

After the Program/Erase Controller completes its operation the Erase Status, Program Status,  $V_{PP}$  Status and Block Protection Status bits should be tested for errors.

**Erase Suspend Status (Bit 6).** The Erase Suspend Status bit (set to '1') indicates that an Erase operation has been suspended or is going to be suspended.

The Erase Suspend Status should only be considered valid when the Program/Erase Controller Status bit is High (Program/Erase Controller inactive). Bit 7 is set within 30 $\mu$ s of the Program/Erase Suspend command being issued therefore the memory may still complete the operation rather than entering the Suspend mode.

When a Program/Erase Resume command is issued the Erase Suspend Status bit returns Low.

**Erase Status (Bit 5).** The Erase Status bit can be used to identify if the memory has failed to verify that the block has erased correctly. When the Erase Status bit is High (set to '1'), the Program/Erase Controller has applied the maximum number of pulses to the block and still failed to verify that the block has erased correctly. The Erase Status bit should be read once the Program/Erase Controller Status bit is High (Program/Erase Controller inactive).

Once set High, the Erase Status bit can only be reset Low by a Clear Status Register command or a hardware reset. If set High it should be reset before a new Program or Erase command is issued, otherwise the new command will appear to fail.

**Program Status (Bit 4).** The Program Status bit is used to identify a Program failure. When the Program Status bit is High (set to '1'), the Program/Erase Controller has applied the maximum number of pulses to the byte and still failed to verify that it has programmed correctly. The Program Status bit should be read once the Program/Erase Controller Status bit is High (Program/Erase Controller inactive).

Once set High, the Program Status bit can only be reset Low by a Clear Status Register command or a hardware reset. If set High it should be reset before a new command is issued, otherwise the new command will appear to fail.

**$V_{PP}$  Status (Bit 3).** The  $V_{PP}$  Status bit can be used to identify an invalid voltage on the  $V_{PP}$  pin during Program and Erase operations. The  $V_{PP}$  pin is only sampled at the beginning of a Program or Erase operation. Indeterminate results can occur if  $V_{PP}$  becomes invalid during an operation.

When the  $V_{PP}$  Status bit is Low (set to '0'), the voltage on the  $V_{PP}$  pin was sampled at a valid voltage; when the  $V_{PP}$  Status bit is High (set to '1'), the  $V_{PP}$  pin has a voltage that is below the  $V_{PP}$  Lockout Voltage,  $V_{PPLK}$ , the memory is protected and Program and Erase operations cannot be performed.

Once set High, the  $V_{PP}$  Status bit can only be reset Low by a Clear Status Register command or a hardware reset. If set High it should be reset before a new Program or Erase command is issued, otherwise the new command will appear to fail.

**Program Suspend Status (Bit 2).** The Program Suspend Status bit (set to '1') indicates that a Program operation has been suspended or is going to be suspended.

The Program Suspend Status should only be considered valid when the Program/Erase Controller Status bit is High (Program/Erase Controller inactive). Bit 2 is set within 5 $\mu$ s of the Program/Erase Suspend command being issued therefore the



memory may still complete the operation rather than entering the Suspend mode.

When a Program/Erase Resume command is issued the Program Suspend Status bit returns Low.

**Block Protection Status (Bit 1).** The Block Protection Status bit can be used to identify if a Program or Erase operation has tried to modify the contents of a protected block.

When the Block Protection Status bit is High (set to '1'), a Program or Erase operation has been attempted on a protected block.

Once set High, the Block Protection Status bit can only be reset Low by a Clear Status Register command or a hardware reset. If set High it should be reset before a new command is issued, otherwise the new command will appear to fail.

**Reserved (Bit 0).** Bit 0 of the Status Register is reserved. Its value must be masked.

**Note: Refer to Appendix C, Flowcharts and Pseudo Codes, for using the Status Register.**

**Table 7. Status Register Bits**

Bit	Name	Logic Level	Definition
7	P/E.C. Status	'1'	Ready
		'0'	Busy
6	Erase Suspend Status	'1'	Suspended
		'0'	In progress or Completed
5	Erase Status	'1'	Erase Error
		'0'	Erase Success
4	Program Status	'1'	Program Error
		'0'	Program Success
3	V <sub>PP</sub> Status	'1'	V <sub>PP</sub> Invalid, Abort
		'0'	V <sub>PP</sub> OK
2	Program Suspend Status	'1'	Suspended
		'0'	In Progress or Completed
1	Block Protection Status	'1'	Program/Erase on protected Block, Abort
		'0'	No operation to protected blocks
0	Reserved		

Note: Logic level '1' is High, '0' is Low.

## M28W160BT, M28W160BB

---

### MAXIMUM RATING

Stressing the device above the rating listed in the Absolute Maximum Ratings table may cause permanent damage to the device. Exposure to Absolute Maximum Rating conditions for extended periods may affect device reliability. These are stress ratings only and operation of the device at

these or any other conditions above those indicated in the Operating sections of this specification is not implied. Refer also to the STMicroelectronics SURE Program and other relevant quality documents.

**Table 8. Absolute Maximum Ratings**

Symbol	Parameter	Value		Unit
		Min	Max	
T <sub>A</sub>	Ambient Operating Temperature <sup>(1)</sup>	-40	85	°C
T <sub>BIAS</sub>	Temperature Under Bias	-40	125	°C
T <sub>STG</sub>	Storage Temperature	-55	155	°C
V <sub>IO</sub>	Input or Output Voltage	-0.6	V <sub>DDQ</sub> +0.6	V
V <sub>DD</sub> , V <sub>DDQ</sub>	Supply Voltage	-0.6	4.1	V
V <sub>PP</sub>	Program Voltage	-0.6	13	V

Note: 1. Depends on range.

**DC AND AC PARAMETERS**

This section summarizes the operating and measurement conditions, and the DC and AC characteristics of the device. The parameters in the DC and AC characteristics Tables that follow, are derived from tests performed under the Measure-

ment Conditions summarized in Table 9, Operating and AC Measurement Conditions. Designers should check that the operating conditions in their circuit match the measurement conditions when relying on the quoted parameters.

**Table 9. Operating and AC Measurement Conditions**

Parameter	M28W160BT, M28W160BB								Units
	70		85		90		100		
	Min	Max	Min	Max	Min	Max	Min	Max	
V <sub>DD</sub> Supply Voltage	2.7	3.6	2.7	3.6	2.7	3.6	2.7	3.6	V
V <sub>DDQ</sub> Supply Voltage (V <sub>DDQ</sub> ≤ V <sub>DD</sub> )	2.7	3.6	2.7	3.6	2.7	3.6	1.65	3.6	V
Ambient Operating Temperature	-40	85	-40	85	-40	85	-40	85	°C
Load Capacitance (C <sub>L</sub> )	50		50		50		50		pF
Input Rise and Fall Times		5		5		5		5	ns
Input Pulse Voltages	0 to V <sub>DDQ</sub>		0 to V <sub>DDQ</sub>		0 to V <sub>DDQ</sub>		0 to V <sub>DDQ</sub>		V
Input and Output Timing Ref. Voltages	V <sub>DDQ</sub> /2		V <sub>DDQ</sub> /2		V <sub>DDQ</sub> /2		V <sub>DDQ</sub> /2		V

**Figure 7. AC Measurement I/O Waveform**

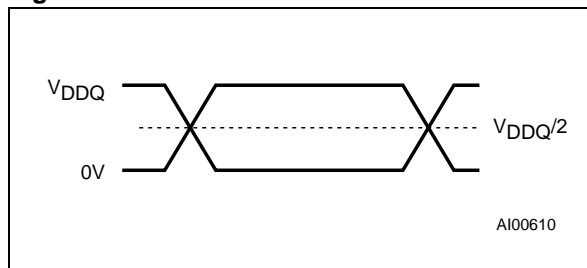

**Figure 8. AC Measurement Load Circuit**

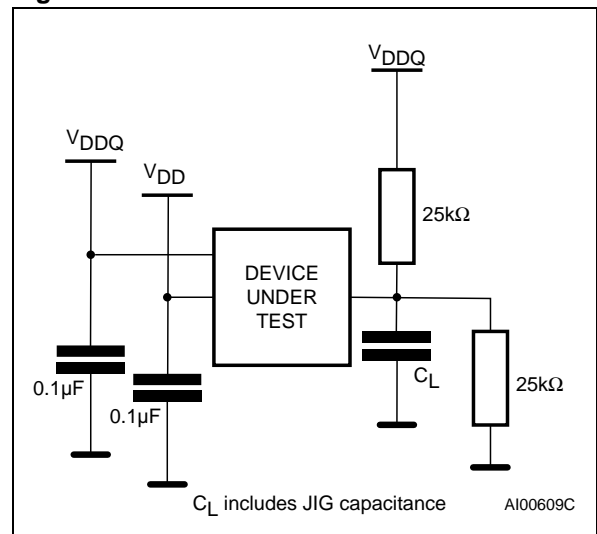

**Table 10. Device Capacitance**

Symbol	Parameter	Test Condition	Min	Max	Unit
C <sub>IN</sub>	Input Capacitance	V <sub>IN</sub> = 0V		6	pF
C <sub>OUT</sub>	Output Capacitance	V <sub>OUT</sub> = 0V		12	pF

Note: Sampled only, not 100% tested.

**Table 11. DC Characteristics**

Symbol	Parameter	Test Condition	Min	Typ	Max	Unit
I <sub>LI</sub>	Input Leakage Current	0V ≤ V <sub>IN</sub> ≤ V <sub>DDQ</sub>			±1	μA
I <sub>LO</sub>	Output Leakage Current	0V ≤ V <sub>OUT</sub> ≤ V <sub>DDQ</sub>			±10	μA
I <sub>DD</sub>	Supply Current (Read)	$\bar{E} = V_{SS}, \bar{G} = V_{IH}, f = 5\text{MHz}$		10	20	mA
I <sub>DD1</sub>	Supply Current (Stand-by or Automatic Stand-by)	$\bar{E} = V_{DDQ} \pm 0.2\text{V},$ $\overline{RP} = V_{DDQ} \pm 0.2\text{V}$		15	50	μA
I <sub>DD2</sub>	Supply Current (Reset)	$\overline{RP} = V_{SS} \pm 0.2\text{V}$		15	50	μA
I <sub>DD3</sub>	Supply Current (Program)	Program in progress V <sub>PP</sub> = 12V ± 5%		10	20	mA
		Program in progress V <sub>PP</sub> = V <sub>DD</sub>		10	20	mA
I <sub>DD4</sub>	Supply Current (Erase)	Erase in progress V <sub>PP</sub> = 12V ± 5%		5	20	mA
		Erase in progress V <sub>PP</sub> = V <sub>DD</sub>		5	20	mA
I <sub>DD5</sub>	Supply Current (Program/Erase Suspend)	$\bar{E} = V_{DDQ} \pm 0.2\text{V},$ Erase suspended			50	μA
I <sub>PP</sub>	Program Current (Read or Stand-by)	V <sub>PP</sub> > V <sub>DD</sub>			400	μA
I <sub>PP1</sub>	Program Current (Read or Stand-by)	V <sub>PP</sub> ≤ V <sub>DD</sub>			5	μA
I <sub>PP2</sub>	Program Current (Reset)	$\overline{RP} = V_{SS} \pm 0.2\text{V}$			5	μA
I <sub>PP3</sub>	Program Current (Program)	Program in progress V <sub>PP</sub> = 12V ± 5%			10	mA
		Program in progress V <sub>PP</sub> = V <sub>DD</sub>			5	μA
I <sub>PP4</sub>	Program Current (Erase)	Erase in progress V <sub>PP</sub> = 12V ± 5%			10	mA
		Erase in progress V <sub>PP</sub> = V <sub>DD</sub>			5	μA
V <sub>IL</sub>	Input Low Voltage		-0.5		0.4	V
		V <sub>DDQ</sub> ≥ 2.7V	-0.5		0.8	V
V <sub>IH</sub>	Input High Voltage		V <sub>DDQ</sub> - 0.4		V <sub>DDQ</sub> + 0.4	V
		V <sub>DDQ</sub> ≥ 2.7V	0.7 V <sub>DDQ</sub>		V <sub>DDQ</sub> + 0.4	V
V <sub>OL</sub>	Output Low Voltage	I <sub>OL</sub> = 100μA, V <sub>DD</sub> = V <sub>DD</sub> min, V <sub>DDQ</sub> = V <sub>DDQ</sub> min			0.1	V
V <sub>OH</sub>	Output High Voltage	I <sub>OH</sub> = -100μA, V <sub>DD</sub> = V <sub>DD</sub> min, V <sub>DDQ</sub> = V <sub>DDQ</sub> min	V <sub>DDQ</sub> - 0.1			V
V <sub>PP1</sub>	Program Voltage (Program or Erase operations)		1.65		3.6	V
V <sub>PPH</sub>	Program Voltage (Program or Erase operations)		11.4		12.6	V
V <sub>PPLK</sub>	Program Voltage (Program and Erase lock-out)				1	V
V <sub>LKO</sub>	V <sub>DD</sub> Supply Voltage (Program and Erase lock-out)				2	V

Figure 9. Read Mode AC Waveforms

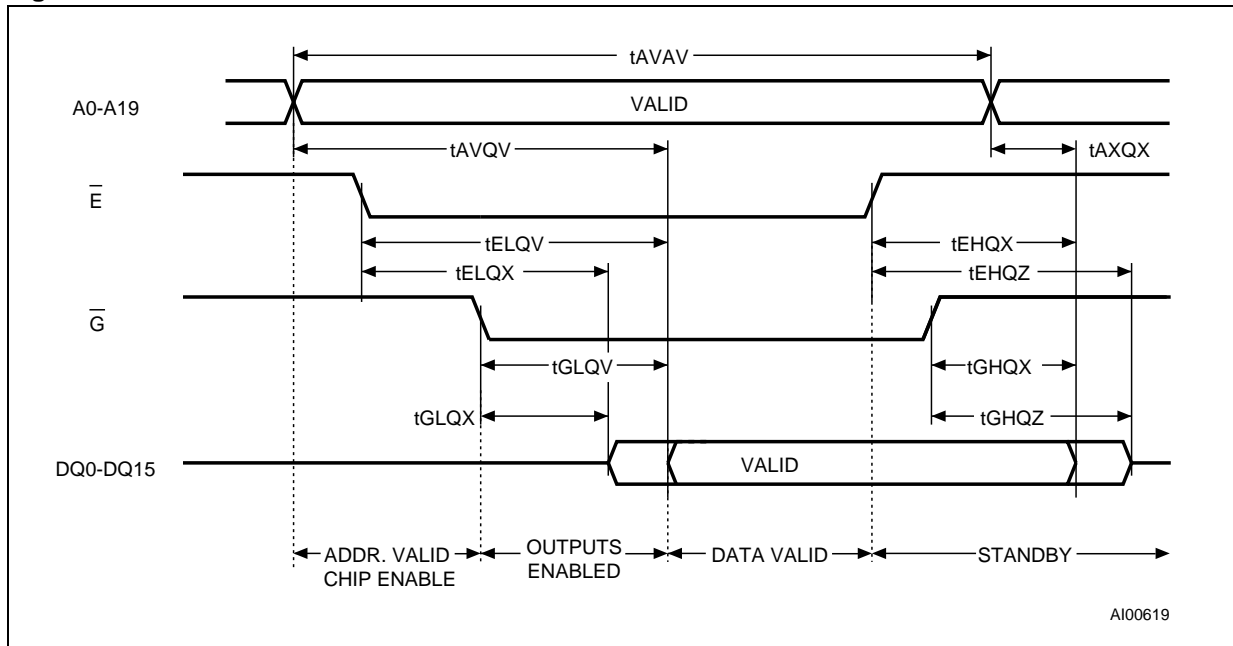

AI00619

Table 12. Read AC Characteristics

Symbol	Alt	Parameter		M28W160B				Unit
				70	85	90	100	
$t_{AVAV}$	$t_{RC}$	Address Valid to Next Address Valid	Min	70	85	90	100	ns
$t_{AVQV}$	$t_{ACC}$	Address Valid to Output Valid	Max	70	85	90	100	ns
$t_{AXQX}^{(1)}$	$t_{OH}$	Address Transition to Output Transition	Min	0	0	0	0	ns
$t_{EHQX}^{(1)}$	$t_{OH}$	Chip Enable High to Output Transition	Min	0	0	0	0	ns
$t_{EHQZ}^{(1)}$	$t_{HZ}$	Chip Enable High to Output Hi-Z	Max	20	20	25	30	ns
$t_{ELQV}^{(2)}$	$t_{CE}$	Chip Enable Low to Output Valid	Max	70	85	90	100	ns
$t_{ELQX}^{(1)}$	$t_{LZ}$	Chip Enable Low to Output Transition	Min	0	0	0	0	ns
$t_{GHQX}^{(1)}$	$t_{OH}$	Output Enable High to Output Transition	Min	0	0	0	0	ns
$t_{GHQZ}^{(1)}$	$t_{DF}$	Output Enable High to Output Hi-Z	Max	20	20	25	30	ns
$t_{GLQV}^{(2)}$	$t_{OE}$	Output Enable Low to Output Valid	Max	20	20	30	35	ns
$t_{GLQX}^{(1)}$	$t_{OLZ}$	Output Enable Low to Output Transition	Min	0	0	0	0	ns

Note: 1. Sampled only, not 100% tested.

2.  $\bar{G}$  may be delayed by up to  $t_{ELQV} - t_{GLQV}$  after the falling edge of  $\bar{E}$  without increasing  $t_{ELQV}$ .

Figure 10. Write AC Waveforms, Write Enable Controlled

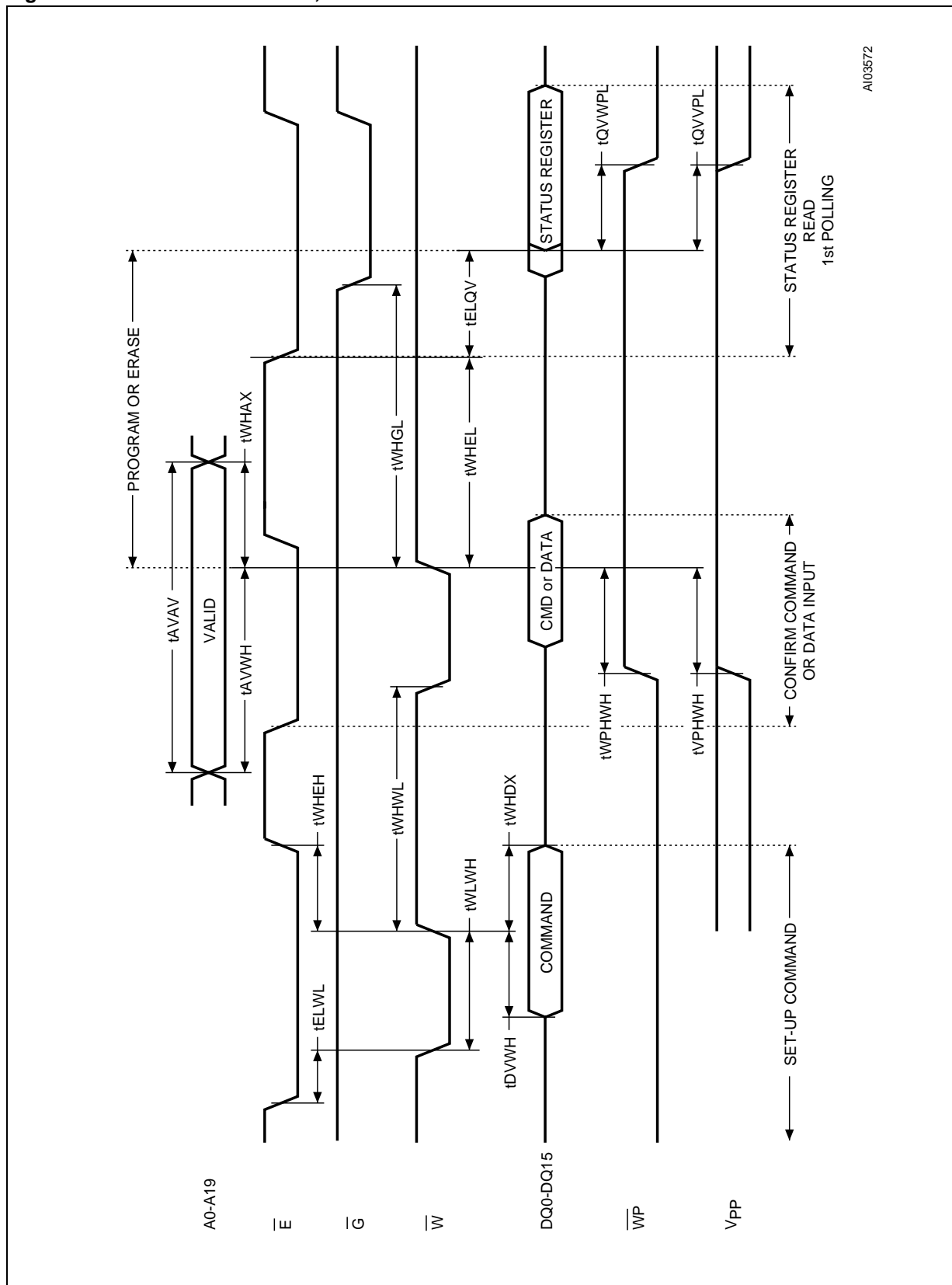

Table 13. Write AC Characteristics, Write Enable Controlled

Symbol	Alt	Parameter		M28W160B				Unit
				70	85	90	100	
t <sub>AVAV</sub>	t <sub>WC</sub>	Write Cycle Time	Min	70	85	90	100	ns
t <sub>AVWH</sub>	t <sub>AS</sub>	Address Valid to Write Enable High	Min	45	45	50	50	ns
t <sub>DVWH</sub>	t <sub>DS</sub>	Data Valid to Write Enable High	Min	45	45	50	50	ns
t <sub>ELWL</sub>	t <sub>CS</sub>	Chip Enable Low to Write Enable Low	Min	0	0	0	0	ns
t <sub>ELQV</sub>		Chip Enable Low to Output Valid	Min	70	85	90	100	ns
t <sub>QVVPL</sub> <sup>(1,2)</sup>		Output Valid to V <sub>PP</sub> Low	Min	0	0	0	0	ns
t <sub>QVWPL</sub>		Output Valid to Write Protect Low	Min	0	0	0	0	ns
t <sub>VPHWH</sub> <sup>(1)</sup>	t <sub>VPS</sub>	V <sub>PP</sub> High to Write Enable High	Min	200	200	200	200	ns
t <sub>WHAX</sub>	t <sub>AH</sub>	Write Enable High to Address Transition	Min	0	0	0	0	ns
t <sub>WHDX</sub>	t <sub>DH</sub>	Write Enable High to Data Transition	Min	0	0	0	0	ns
t <sub>WHEH</sub>	t <sub>CH</sub>	Write Enable High to Chip Enable High	Min	0	0	0	0	ns
t <sub>WHEL</sub>		Write Enable High to Chip Enable Low	Min	25	25	30	30	ns
t <sub>WHGL</sub>		Write Enable High to Output Enable Low	Min	20	20	30	30	ns
t <sub>WHWL</sub>	t <sub>WPH</sub>	Write Enable High to Write Enable Low	Min	25	25	30	30	ns
t <sub>WLWH</sub>	t <sub>WP</sub>	Write Enable Low to Write Enable High	Min	45	45	50	50	ns
t <sub>WPHWH</sub>		Write Protect High to Write Enable High	Min	45	45	50	50	ns

Note: 1. Sampled only, not 100% tested.

2. Applicable if V<sub>PP</sub> is seen as a logic input (V<sub>PP</sub> < 3.6V).

Figure 11. Write AC Waveforms, Chip Enable Controlled

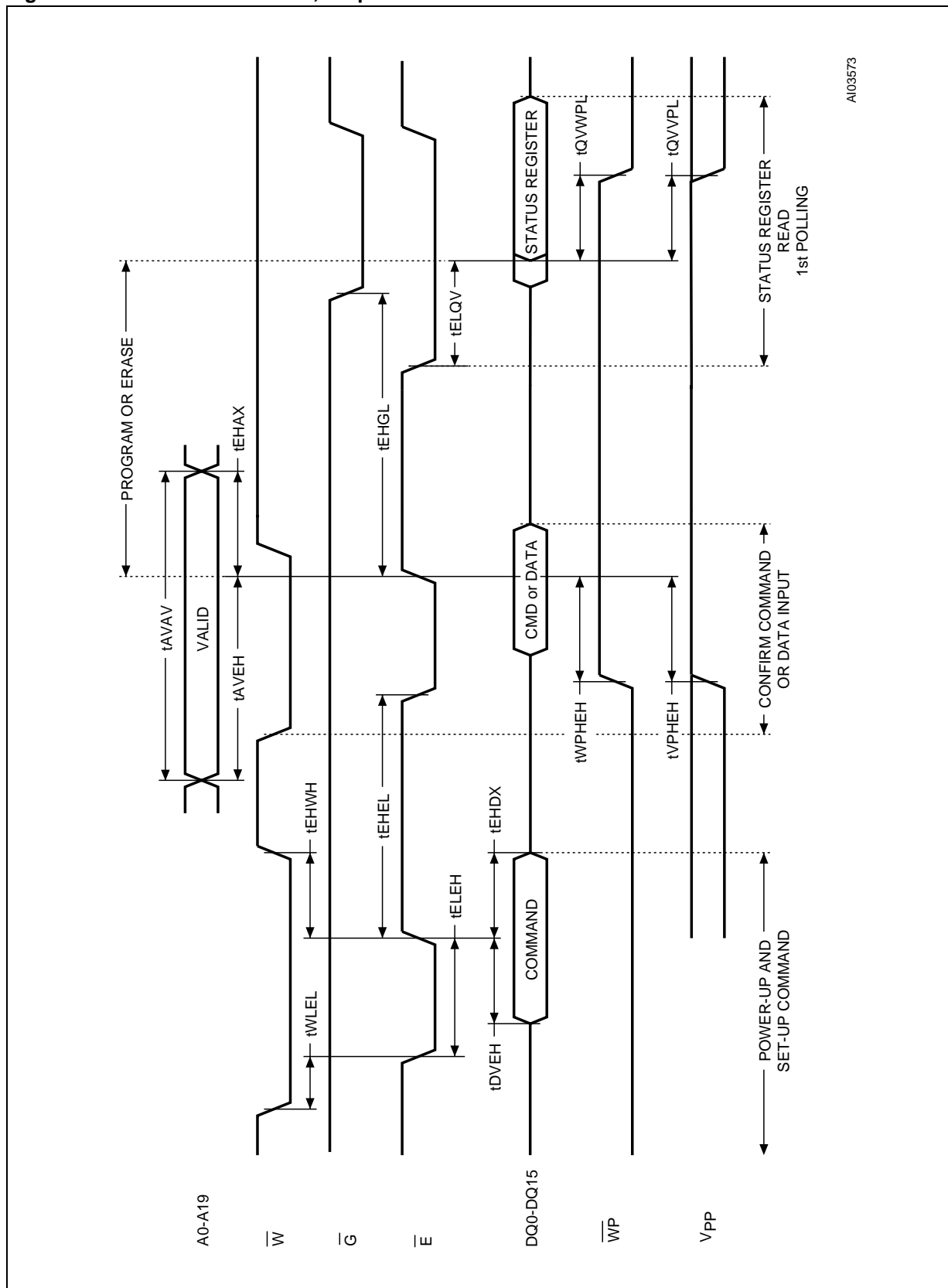

AI03573



Table 14. Write AC Characteristics, Chip Enable Controlled

Symbol	Alt	Parameter		M28W160B				Unit
				70	85	90	100	
t <sub>AVAV</sub>	t <sub>WC</sub>	Write Cycle Time	Min	70	85	90	100	ns
t <sub>AVEH</sub>	t <sub>AS</sub>	Address Valid to Chip Enable High	Min	45	45	50	50	ns
t <sub>DVEH</sub>	t <sub>DS</sub>	Data Valid to Chip Enable High	Min	45	45	50	50	ns
t <sub>EHAX</sub>	t <sub>AH</sub>	Chip Enable High to Address Transition	Min	0	0	0	0	ns
t <sub>EHDX</sub>	t <sub>DH</sub>	Chip Enable High to Data Transition	Min	0	0	0	0	ns
t <sub>EHHL</sub>	t <sub>CPH</sub>	Chip Enable High to Chip Enable Low	Min	25	25	30	30	ns
t <sub>EHGL</sub>		Chip Enable High to Output Enable Low	Min	25	25	30	30	ns
t <sub>EHWH</sub>	t <sub>WH</sub>	Chip Enable High to Write Enable High	Min	0	0	0	0	ns
t <sub>LELH</sub>	t <sub>CP</sub>	Chip Enable Low to Chip Enable High	Min	45	45	50	50	ns
t <sub>ELQV</sub>		Chip Enable Low to Output Valid	Min	70	85	90	100	ns
t <sub>QVVPL</sub> <sup>(1,2)</sup>		Output Valid to V <sub>PP</sub> Low	Min	0	0	0	0	ns
t <sub>QVWPL</sub>		Data Valid to Write Protect Low	Min	0	0	0	0	ns
t <sub>VPHEH</sub> <sup>(1)</sup>	t <sub>VPS</sub>	V <sub>PP</sub> High to Chip Enable High	Min	200	200	200	200	ns
t <sub>WLEL</sub>	t <sub>CS</sub>	Write Enable Low to Chip Enable Low	Min	0	0	0	0	ns
t <sub>WPHEH</sub>		Write Protect High to Chip Enable High	Min	45	45	50	50	ns

Note: 1. Sampled only, not 100% tested.

2. Applicable if V<sub>PP</sub> is seen as a logic input (V<sub>PP</sub> < 3.6V).

Figure 12. Power-Up and Reset AC Waveforms

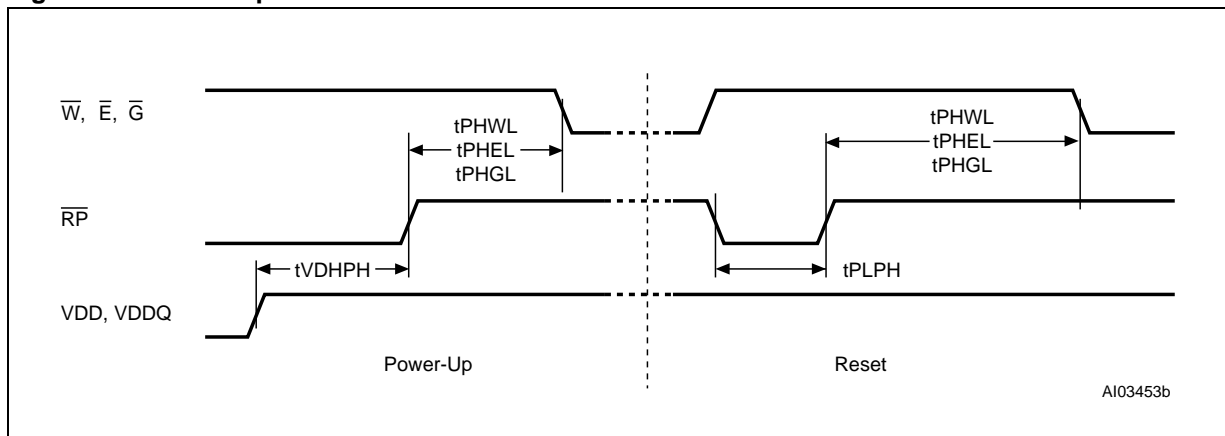

Table 15. Power-Up and Reset AC Characteristics

Symbol	Parameter	Test Condition		M28W160B				Unit
				70	85	90	100	
t <sub>PHWL</sub> t <sub>PEHL</sub> t <sub>PHGL</sub>	Reset High to Write Enable Low, Chip Enable Low, Output Enable Low	During Program and Erase	Min	50	50	50	50	μs
		others	Min	30	30	30	30	ns
t <sub>PLPH</sub> <sup>(1,2)</sup>	Reset Low to Reset High		Min	100	100	100	100	ns
t <sub>VDHPH</sub> <sup>(3)</sup>	Supply Voltages High to Reset High		Min	50	50	50	50	μs

Note: 1. The device Reset is possible but not guaranteed if t<sub>PLPH</sub> < 100ns.

2. Sampled only, not 100% tested.

3. It is important to assert  $\overline{RP}$  in order to allow proper CPU initialization during power up or reset.

PACKAGE MECHANICAL

Figure 13. TSOP48 - 48 lead Plastic Thin Small Outline, 12 x 20mm, Package Outline

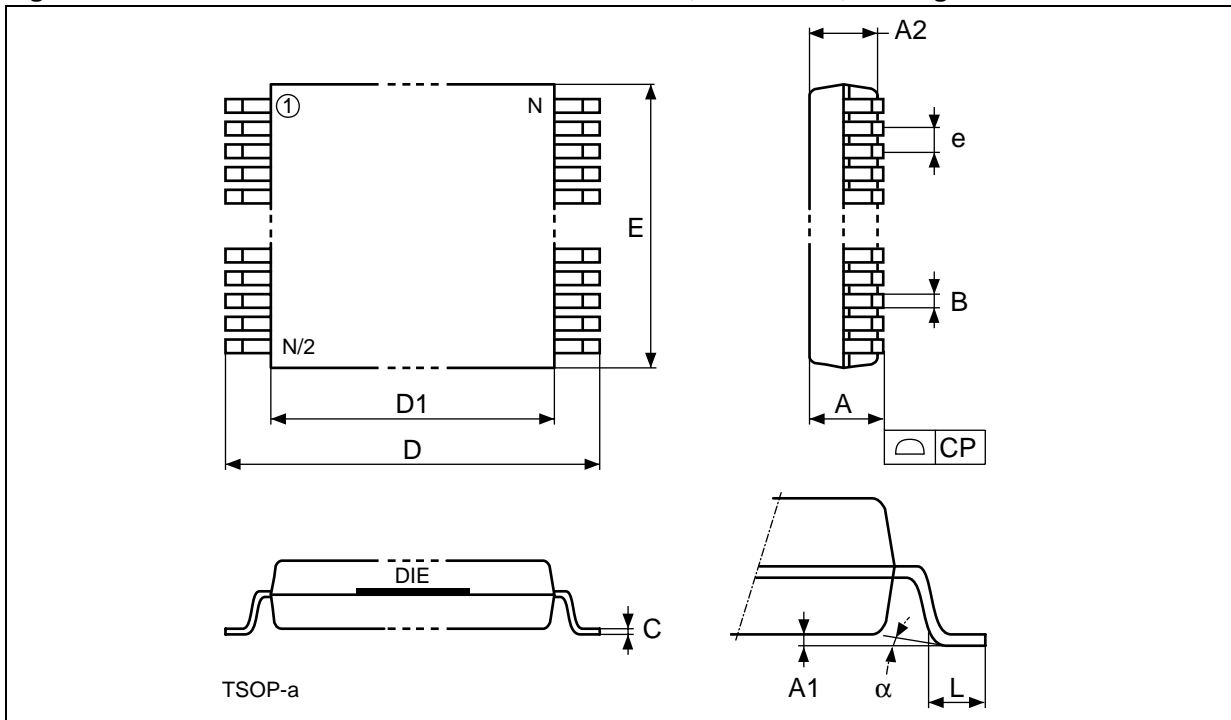

Note: Drawing is not to scale.

Table 16. TSOP48 - 48 lead Plastic Thin Small Outline, 12 x 20mm, Package Mechanical Data

Symbol	mm			inches		
	Typ	Min	Max	Typ	Min	Max
A			1.20			0.0472
A1		0.05	0.15		0.0020	0.0059
A2		0.95	1.05		0.0374	0.0413
B		0.17	0.27		0.0067	0.0106
C		0.10	0.21		0.0039	0.0083
D		19.80	20.20		0.7795	0.7953
D1		18.30	18.50		0.7205	0.7283
E		11.90	12.10		0.4685	0.4764
e	0.50	-	-	0.0197	-	-
L		0.50	0.70		0.0197	0.0279
alpha		0°	5°		0°	5°
N	48			48		
CP			0.10			0.0039

## M28W160BT, M28W160BB

Figure 14.  $\mu$ BGA46 6.39x6.37mm - 8 x 6 ball array, 0.75 mm pitch, Bottom View Package Outline

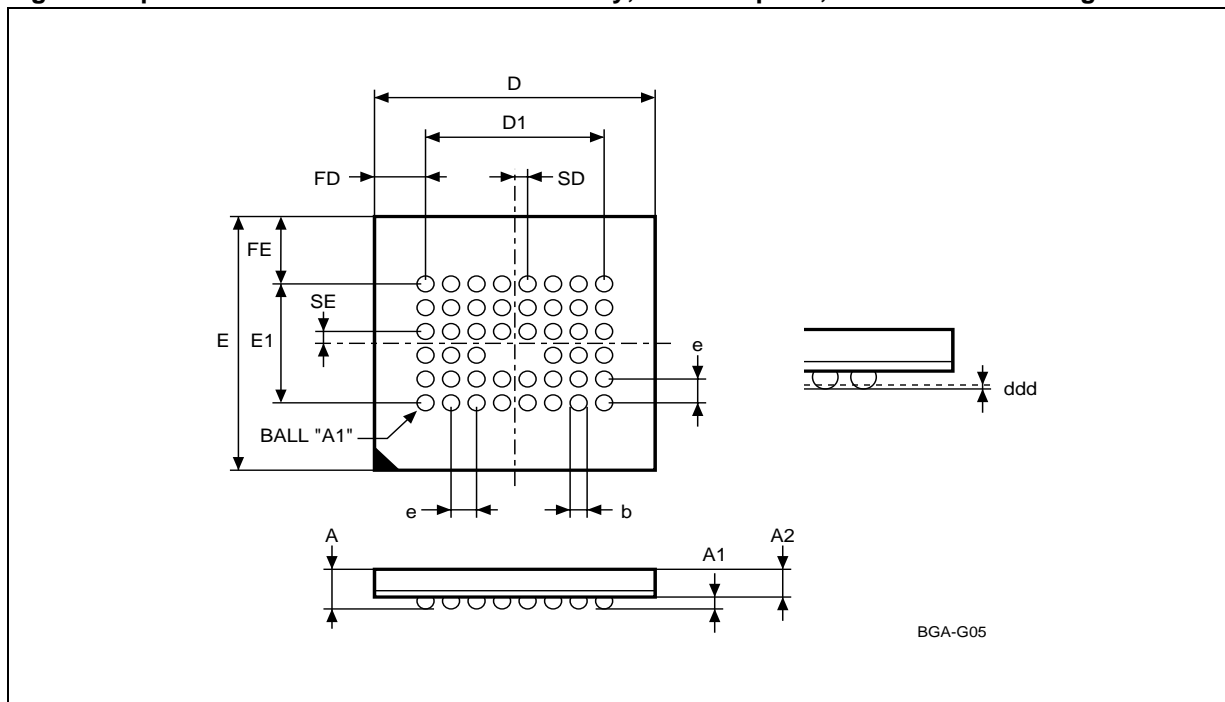

Note: Drawing is not to scale

Table 17.  $\mu$ BGA46 6.39x6.37mm - 8 x 6 ball array, 0.75 mm pitch, Package Mechanical Data

Symbol	mm			inch		
	Typ	Min	Max	Typ	Min	Max
A			1.000			0.0394
A1		0.180			0.0071	
A2	0.700	–	–	0.0276	–	–
b	0.350	0.300	0.400	0.0138	0.0118	0.0157
D	6.390	6.340	6.440	0.2516	0.2496	0.2535
D1	5.250	–	–	0.2067	–	–
ddd			0.008			0.0003
e	0.750	–	–	0.0295	–	–
E	6.370	6.320	6.420	0.2508	0.2488	0.2528
E1	3.750	–	–	0.1476	–	–
FD	0.570	–	–	0.0224	–	–
FE	1.310	–	–	0.0516	–	–
SD	0.375	–	–	0.0148	–	–
SE	0.375	–	–	0.0148	–	–

Figure 15.  $\mu$ BGA46 Daisy Chain - Package Connections (Top view through package)

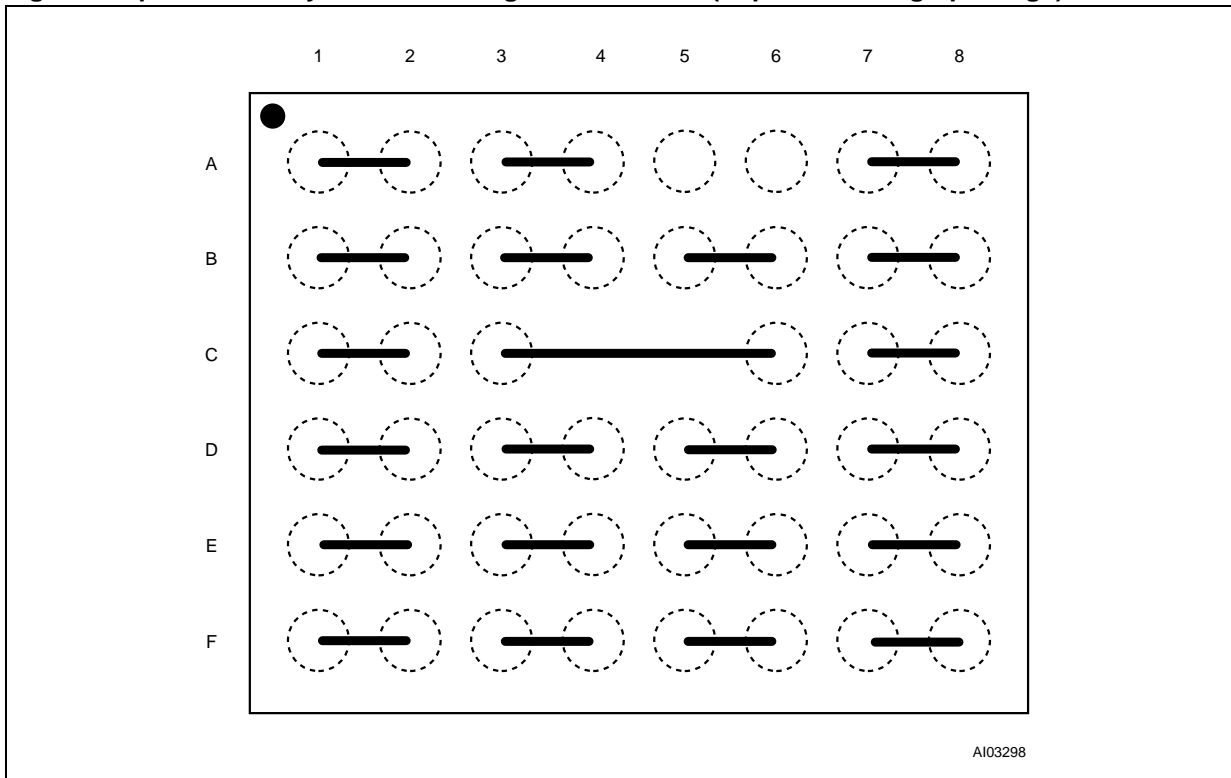
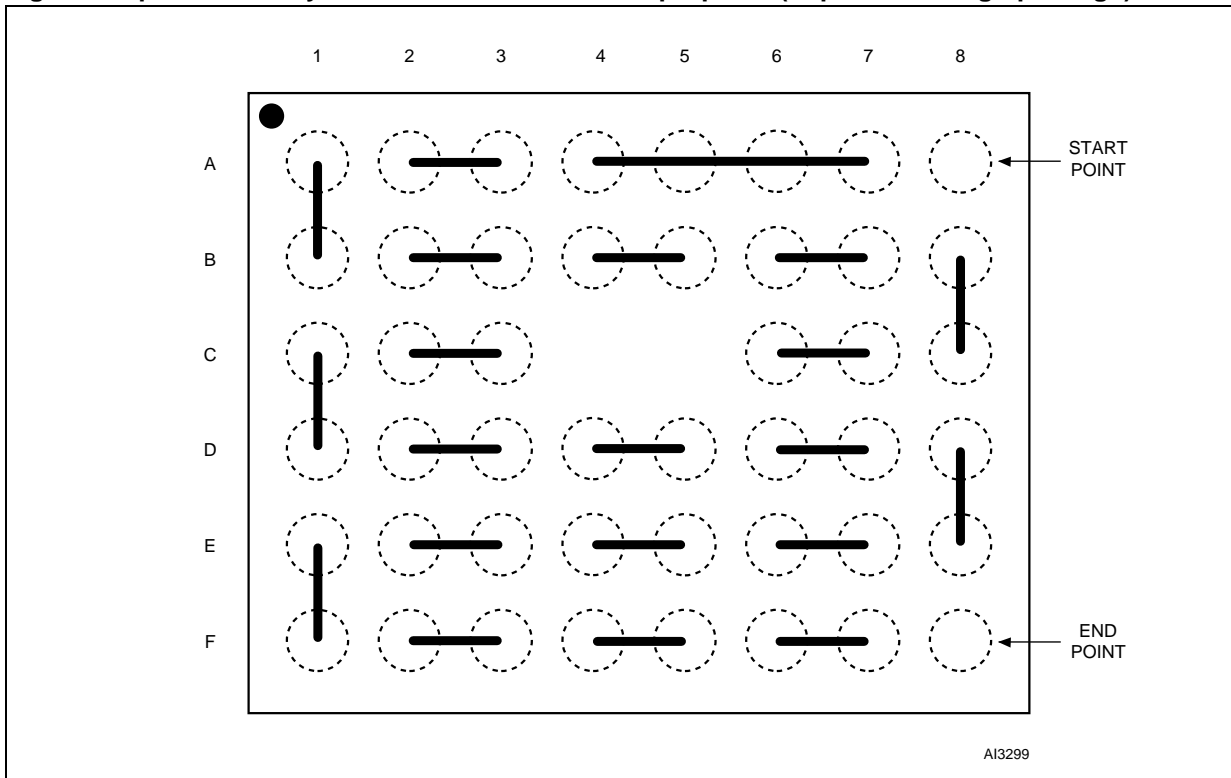
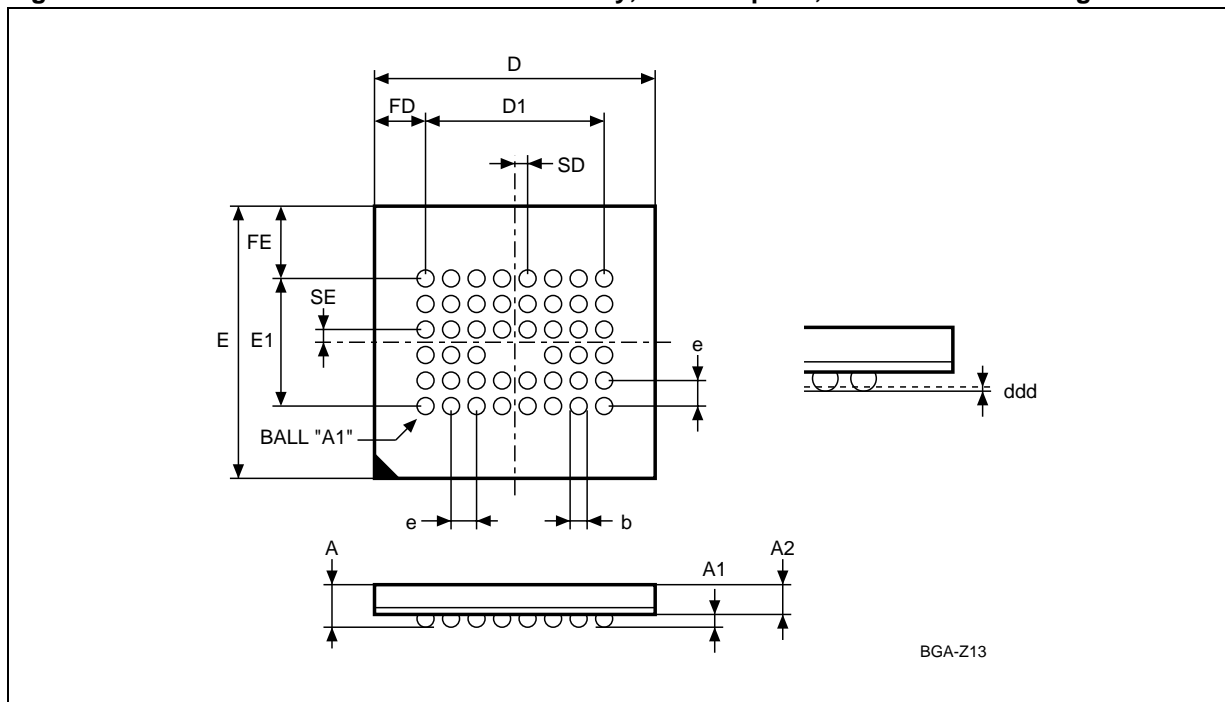

Figure 16.  $\mu$ BGA46 Daisy Chain - PCB Connections proposal (Top view through package)



**M28W160BT, M28W160BB**

**Figure 17. TFBGA46 6.39x6.37mm - 8x6 ball array, 0.75mm pitch, Bottom View Package Outline**



Drawing is not to scale.

**Table 18. TFBGA46 6.39x6.37mm - 8x6 ball array, 0.75mm pitch, Package Mechanical Data**

Symbol	millimeters			inches		
	Typ	Min	Max	Typ	Min	Max
A			1.200			0.0472
A1		0.200			0.0079	
A2			1.000			0.0394
b	0.400	0.350	0.450	0.0157	0.0138	0.0177
D	6.390	6.290	6.490	0.2516	0.2476	0.2555
D1	5.250	–	–	0.2067	–	–
ddd			0.100			0.0039
E	6.370	6.270	6.470	0.2508	0.2469	0.2547
e	0.750	–	–	0.0295	–	–
E1	3.750	–	–	0.1476	–	–
FD	0.570	–	–	0.0224	–	–
FE	1.310	–	–	0.0516	–	–
SD	0.375	–	–	0.0148	–	–
SE	0.375	–	–	0.0148	–	–

Figure 18. TFBGA46 Daisy Chain - Package Connections (Top view through package)

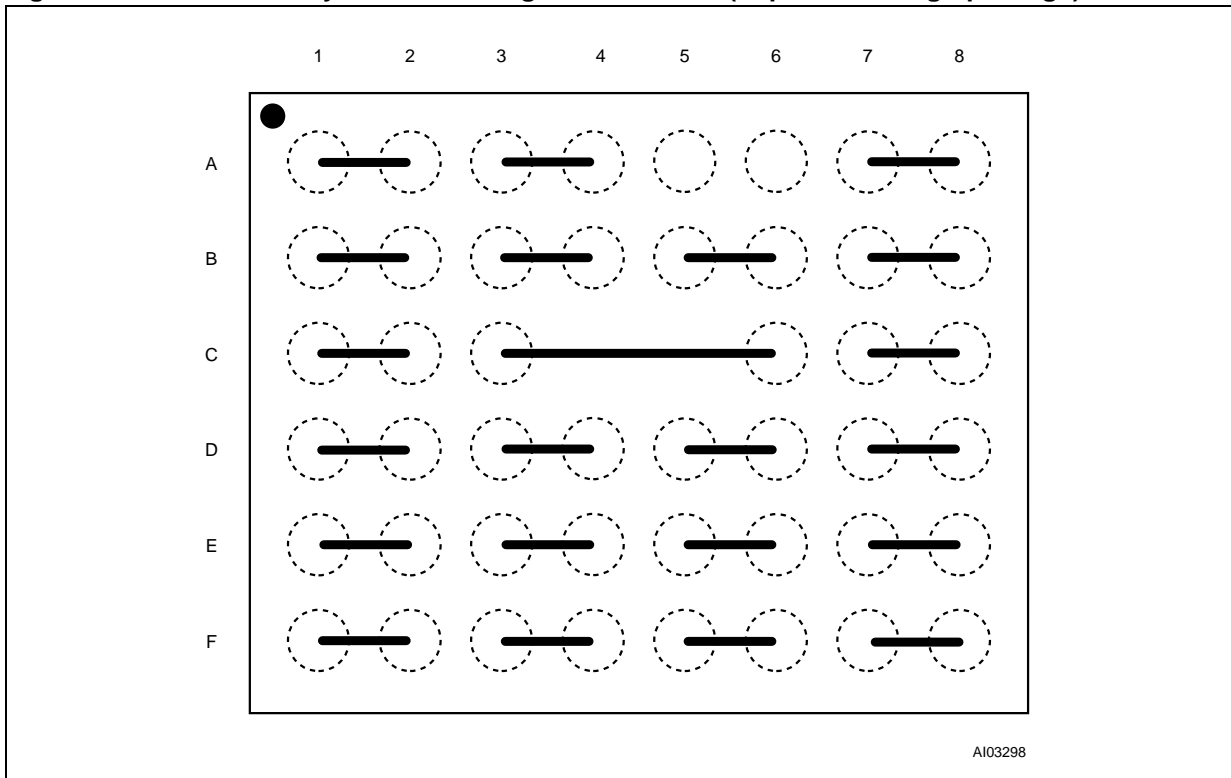
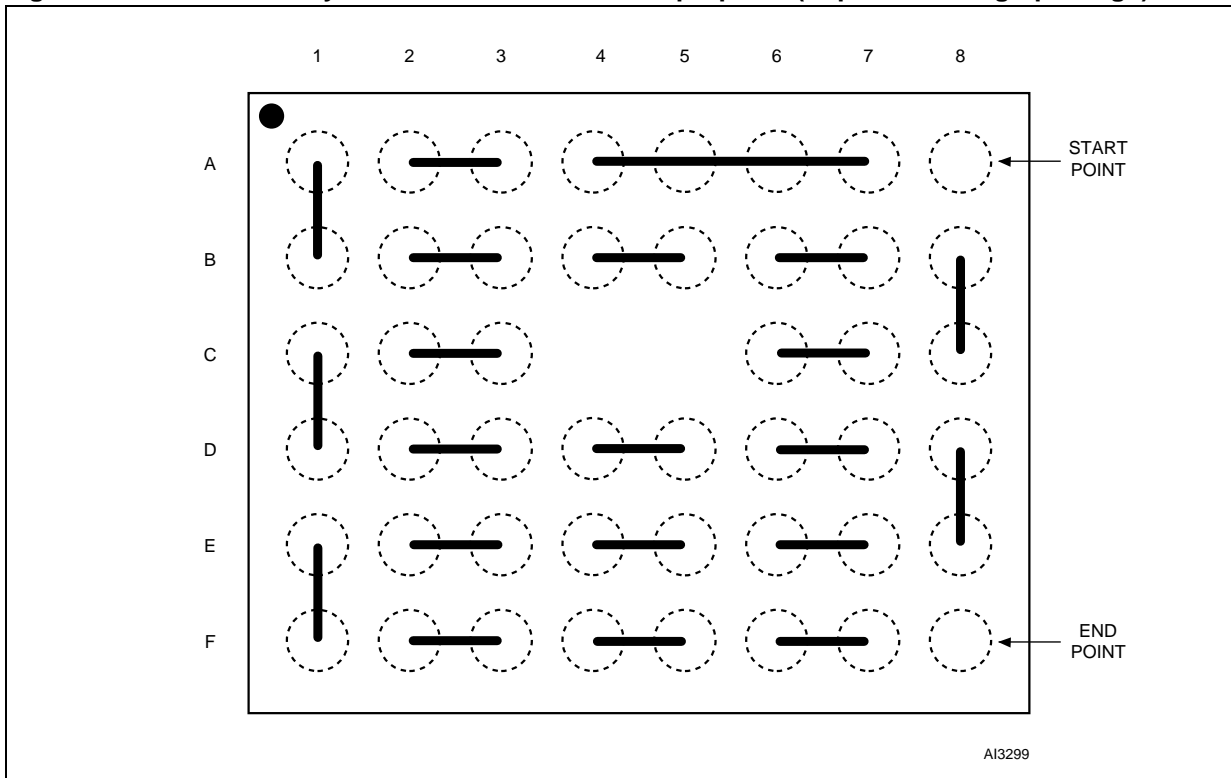

Figure 19. TFBGA46 Daisy Chain - PCB Connections proposal (Top view through package)



## M28W160BT, M28W160BB

### PART NUMBERING

**Table 19. Ordering Information Scheme**

Example:	M28W160BT	90	N	6	T
<b>Device Type</b>	M28				
<b>Operating Voltage</b>	W = $V_{DD} = 2.7V$ to $3.6V$ ; $V_{DDQ} = 1.65V$ to $3.6V$				
<b>Device Function</b>	160B = 16 Mbit (x16), Boot Block				
<b>Array Matrix</b>	T = Top Boot B = Bottom Boot				
<b>Speed</b>	70 = 70 ns 85 = 85 ns 90 = 90 ns 100 = 100 ns				
<b>Package</b>	N = TSOP48: 12 x 20 mm GB = $\mu$ BGA46: 6.39 x 6.37mm, 0.75 mm pitch ZB = TFBGA46: 6.39 x 6.37mm, 0.75 mm pitch				
<b>Temperature Range</b>	1 = 0 to 70 °C 6 = -40 to 85 °C				
<b>Option</b>	T = Tape & Reel Packing				

**Table 20. Daisy Chain Ordering Scheme**

Example:	M28W160B	-GB	T
<b>Device Type</b>	M28W160B		
<b>Daisy Chain</b>	-GB = $\mu$ BGA46: 6.39 x 6.37mm, 0.75 mm pitch -ZB = TFBGA46: 6.39 x 6.37mm, 0.75 mm pitch		
<b>Option</b>	T = Tape & Reel Packing		

Note: Devices are shipped from the factory with the memory content bits erased to '1'. For a list of available options (Speed, Package, etc...) or for further information on any aspect of this device, please contact the ST Sales Office nearest to you.



## REVISION HISTORY

Table 21. Document Revision History

Date	Version	Revision Details
July 1999	-01	First Issue
9/21/99	-02	Parameter Block Erase Typ. specification change Added $t_{WHGL}$ and $t_{EHGL}$
10/20/99	-03	$\mu$ BGA Package Mechanical Data change Daisy Chain diagrams, Package and PCB Connections, added
2/09/00	-04	Access Time conditions change Reset mode function change to remove Power Down mode Instructions description clarification Change of Parameter Block Erase value Block Protections description clarification Security Code Area definition change $I_{DD2}$ and $I_{DD3}$ value change $t_{PLRH}$ value change Program, Erase, Command Interface flowcharts clarification Package Mechanical Data change $\mu$ BGA Package Outline diagram change
4/19/00	-05	Daisy Chain part numbering defined $\mu$ BGA Daisy Chain diagrams, Package and PCB Connections re-designed
5/17/00	-06	$\mu$ BGA Package Outline diagram change
1/15/01	-07	TFBGA Package added CFI specification clarification
3/06/01	-08	Document type : from Preliminary Data to Data Sheet 70ns Speed Class added
3/12/01	-09	
4/13/01	-10	Completely rewritten and restructured, 85ns speed class added.
5/29/01	-11	Corrections made to CFI data.
31-May-2001	-12	Corrections to TFBGA46 package dimensions.
30-Oct-2001	-13	$V_{DDQ}$ Maximum changed to 3.3V Commands Table, Read CFI Query Address on 1st cycle changed to 'X' (Table 3) $t_{WHEL}$ description clarified (Table 13)
16-May-2002	-14	$V_{DDQ}$ Maximum changed to 3.6V, TFBGA and $\mu$ BGA package dimensions added to descriptions.

**APPENDIX A. BLOCK ADDRESS TABLES**

**Table 22. Top Boot Block Addresses, M28W160BT**

#	Size (KWord)	Address Range
0	4	FF000-FFFFF
1	4	FE000-FEFFF
2	4	FD000-FDFFF
3	4	FC000-FCFFF
4	4	FB000-FBFFF
5	4	FA000-FAFFF
6	4	F9000-F9FFF
7	4	F8000-F8FFF
8	32	F0000-F7FFF
9	32	E8000-EFFFF
10	32	E0000-E7FFF
11	32	D8000-DFFFF
12	32	D0000-D7FFF
13	32	C8000-CFFFF
14	32	C0000-C7FFF
15	32	B8000-BFFFF
16	32	B0000-B7FFF
17	32	A8000-AFFFF
18	32	A0000-A7FFF
19	32	98000-9FFFF
20	32	90000-97FFF
21	32	88000-8FFFF
22	32	80000-87FFF
23	32	78000-7FFFF
24	32	70000-77FFF
25	32	68000-6FFFF
26	32	60000-67FFF
27	32	58000-5FFFF
28	32	50000-57FFF
29	32	48000-4FFFF
30	32	40000-47FFF
31	32	38000-3FFFF
32	32	30000-37FFF
33	32	28000-2FFFF
34	32	20000-27FFF
35	32	18000-1FFFF
36	32	10000-17FFF
37	32	08000-0FFFF
38	32	00000-07FFF

**Table 23. Bottom Boot Block Addresses, M28W160BB**

#	Size (KWord)	Address Range
38	32	F8000-FFFFF
37	32	F0000-F7FFF
36	32	E8000-EFFFF
35	32	E0000-E7FFF
34	32	D8000-DFFFF
33	32	D0000-D7FFF
32	32	C8000-CFFFF
31	32	C0000-C7FFF
30	32	B8000-BFFFF
29	32	B0000-B7FFF
28	32	A8000-AFFFF
27	32	A0000-A7FFF
26	32	98000-9FFFF
25	32	90000-97FFF
24	32	88000-8FFFF
23	32	80000-87FFF
22	32	78000-7FFFF
21	32	70000-77FFF
20	32	68000-6FFFF
19	32	60000-67FFF
18	32	58000-5FFFF
17	32	50000-57FFF
16	32	48000-4FFFF
15	32	40000-47FFF
14	32	38000-3FFFF
13	32	30000-37FFF
12	32	28000-2FFFF
11	32	20000-27FFF
10	32	18000-1FFFF
9	32	10000-17FFF
8	32	08000-0FFFF
7	4	07000-07FFF
6	4	06000-06FFF
5	4	05000-05FFF
4	4	04000-04FFF
3	4	03000-03FFF
2	4	02000-02FFF
1	4	01000-01FFF
0	4	00000-00FFF

**APPENDIX B. COMMON FLASH INTERFACE (CFI)**

The Common Flash Interface is a JEDEC approved, standardized data structure that can be read from the Flash memory device. It allows a system software to query the device to determine various electrical and timing parameters, density information and functions supported by the memory. The system can interface easily with the device, enabling the software to upgrade itself when necessary.

When the CFI Query Command (RCFI) is issued the device enters CFI Query mode and the data

structure is read from the memory. Tables 24, 25, 26, 27, 28 and 29 show the addresses used to retrieve the data.

The CFI data structure also contains a security area where a 64 bit unique security number is written (see Table 29, Security Code area). This area can be accessed only in Read mode by the final user. It is impossible to change the security number after it has been written by ST. Issue a Read command to return to Read mode.

**Table 24. Query Structure Overview**

Offset	Sub-section Name	Description
00h	Reserved	Reserved for algorithm-specific information
10h	CFI Query Identification String	Command set ID and algorithm data offset
1Bh	System Interface Information	Device timing & voltage information
27h	Device Geometry Definition	Flash device layout
P	Primary Algorithm-specific Extended Query table	Additional information specific to the Primary Algorithm (optional)
A	Alternate Algorithm-specific Extended Query table	Additional information specific to the Alternate Algorithm (optional)

Note: Query data are always presented on the lowest order data outputs.

**Table 25. CFI Query Identification String**

Offset	Data	Description	Value
00h	0020h	Manufacturer Code	ST
01h	0090h 0091h	Device Code	Top Bottom
02h-0Fh	reserved	Reserved	
10h	0051h	Query Unique ASCII String "QRY"	"Q"
11h	0052h	Query Unique ASCII String "QRY"	"R"
12h	0059h	Query Unique ASCII String "QRY"	"Y"
13h 14h	0003h 0000h	Primary Algorithm Command Set and Control Interface ID code 16 bit ID code defining a specific algorithm	Intel Compatible
15h 16h	offset = P = 0035h 0000h	Address for Primary Algorithm extended Query table	P=35h
17h 18h	0000h 0000h	Alternate Vendor Command Set and Control Interface ID Code second vendor - specified algorithm supported (note: 0000h means none exists)	NA
19h 1Ah	value = A = 0000h 0000h	Address for Alternate Algorithm extended Query table note: 0000h means none exists	NA

Note: Query data are always presented on the lowest order data outputs (DQ7-DQ0) only. DQ8-DQ15 are '0'.

**Table 26. CFI Query System Interface Information**

Offset	Data	Description	Value
1Bh	0027h	V <sub>DD</sub> Logic Supply Minimum Program/Erase or Write voltage bit 7 to 4 BCD value in volts bit 3 to 0 BCD value in 100 mV	2.7V
1Ch	0036h	V <sub>DD</sub> Logic Supply Maximum Program/Erase or Write voltage bit 7 to 4 BCD value in volts bit 3 to 0 BCD value in 100 mV	3.6V
1Dh	00B4h	V <sub>PP</sub> [Programming] Supply Minimum Program/Erase voltage bit 7 to 4 HEX value in volts bit 3 to 0 BCD value in 100 mV	11.4V
1Eh	00C6h	V <sub>PP</sub> [Programming] Supply Maximum Program/Erase voltage bit 7 to 4 HEX value in volts bit 3 to 0 BCD value in 100 mV	12.6V
1Fh	0004h	Typical timeout per single word program = 2 <sup>n</sup> μs	16μs
20h	0004h	Typical timeout for Double Word Program = 2 <sup>n</sup> μs	16μs
21h	000Ah	Typical timeout per individual block erase = 2 <sup>n</sup> ms	1 s
22h	0000h	Typical timeout for full chip erase = 2 <sup>n</sup> ms	NA
23h	0005h	Maximum timeout for word program = 2 <sup>n</sup> times typical	512μs
24h	0005h	Maximum timeout for Double Word Program = 2 <sup>n</sup> times typical	512μs
25h	0003h	Maximum timeout per individual block erase = 2 <sup>n</sup> times typical	8 s
26h	0000h	Maximum timeout for chip erase = 2 <sup>n</sup> times typical	NA

Table 27. Device Geometry Definition

Offset Word Mode	Data	Description	Value
27h	0015h	Device Size = $2^n$ in number of bytes	2MByte
28h 29h	0001h 0000h	Flash Device Interface Code description	x16 Async
2Ah 2Bh	0002h 0000h	Maximum number of bytes in multi-byte program or page = $2^n$	4
2Ch	0002h	Number of Erase Block Regions within the device. It specifies the number of regions within the device containing contiguous Erase Blocks of the same size.	2
M28W160BT	2Dh 2Eh	Region 1 Information Number of identical-size erase block = 001Eh+1	31
	2Fh 30h	Region 1 Information Block size in Region 1 = 0100h * 256 byte	64KByte
	31h 32h	Region 2 Information Number of identical-size erase block = 0007h+1	8
	33h 34h	Region 2 Information Block size in Region 2 = 0020h * 256 byte	8KByte
M28W160BB	2Dh 2Eh	Region 1 Information Number of identical-size erase block = 0007h+1	8
	2Fh 30h	Region 1 Information Block size in Region 1 = 0020h * 256 byte	8KByte
	31h 32h	Region 2 Information Number of identical-size erase block = 001Eh+1	31
	33h 34h	Region 2 Information Block size in Region 2 = 0100h * 256 byte	64KByte



APPENDIX C. FLOWCHARTS AND PSEUDO CODES

Figure 20. Program Flowchart and Pseudo Code

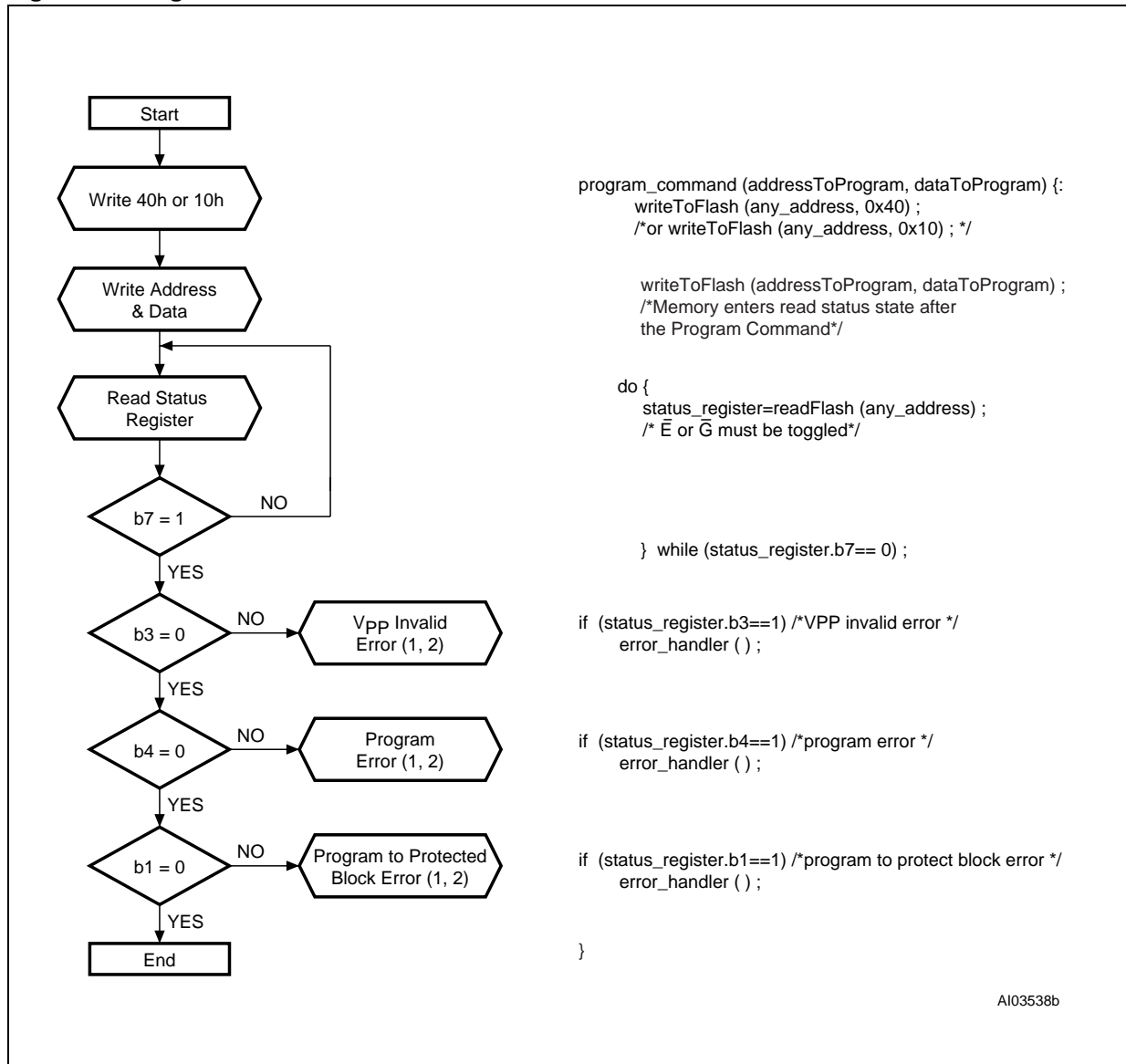

Note: 1. Status check of b1 (Protected Block), b3 (Vpp Invalid) and b4 (Program Error) can be made after each program operation or after a sequence.  
 2. If an error is found, the Status Register must be cleared before further Program/Erase Controller operations.

Figure 21. Double Word Program Flowchart and Pseudo Code

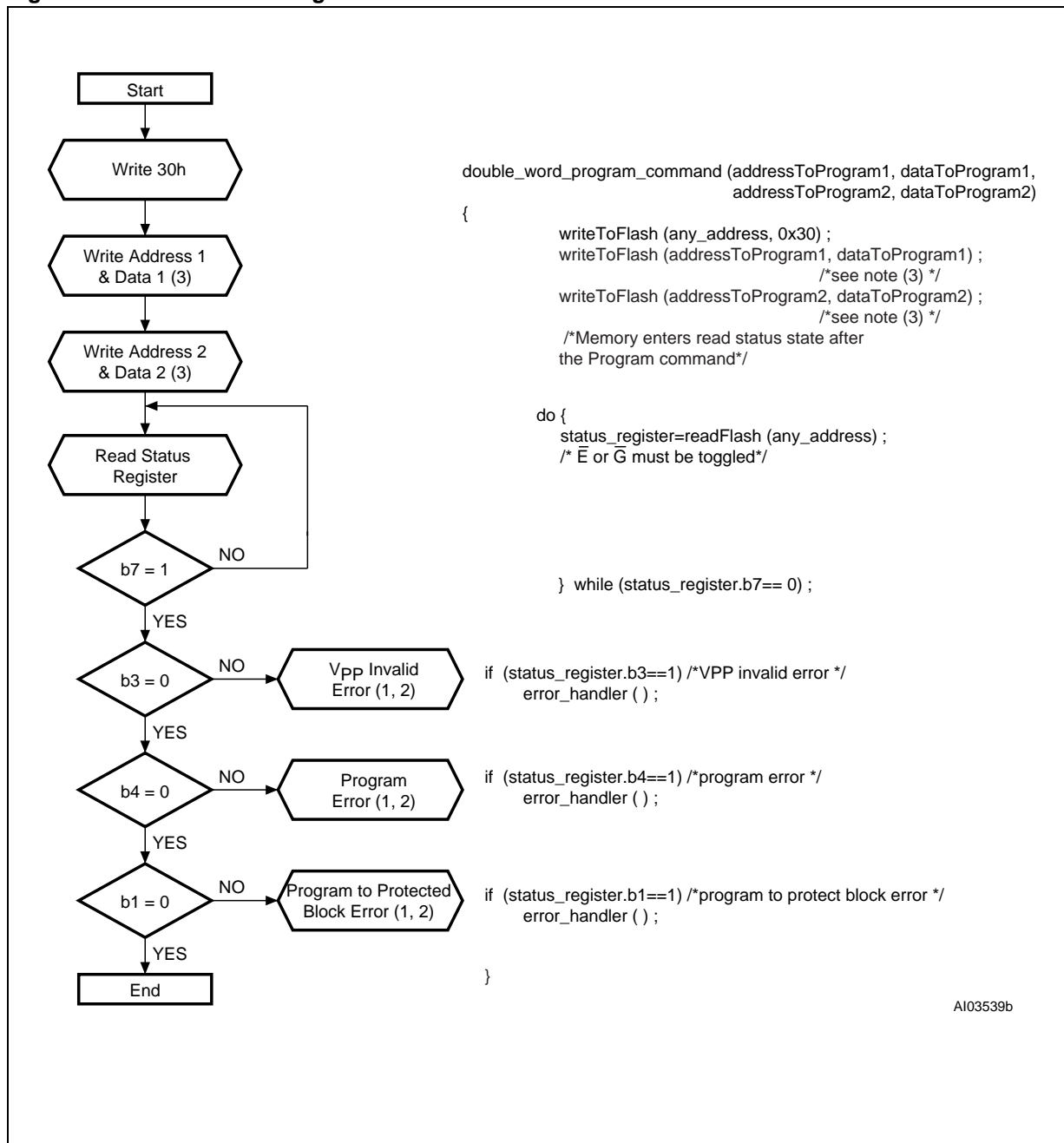

- Note: 1. Status check of b1 (Protected Block), b3 (Vpp Invalid) and b4 (Program Error) can be made after each program operation or after a sequence.  
 2. If an error is found, the Status Register must be cleared before further Program/Erase operations.  
 3. Address 1 and Address 2 must be consecutive addresses differing only for bit A0.



Figure 22. Program Suspend & Resume Flowchart and Pseudo Code

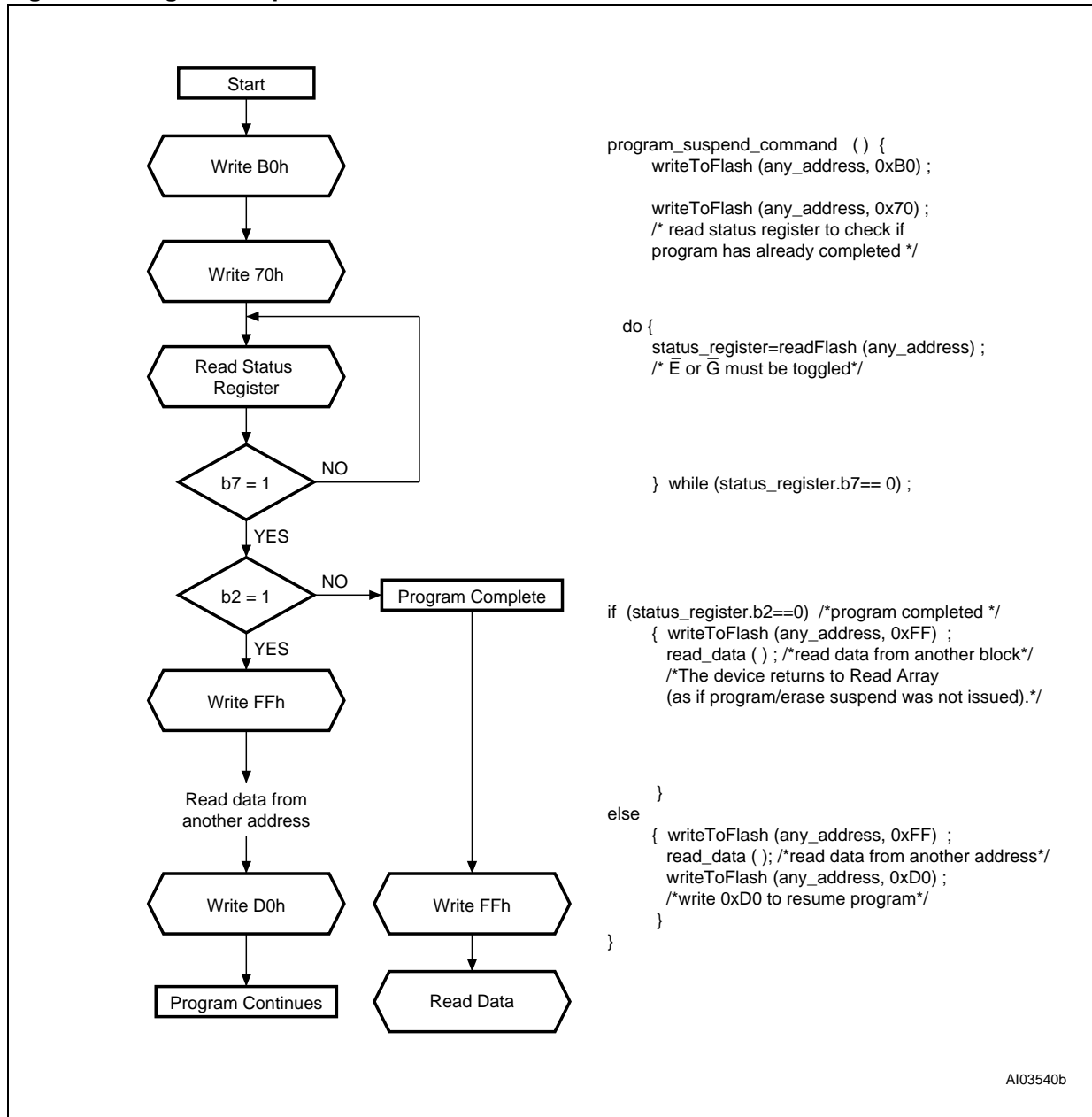
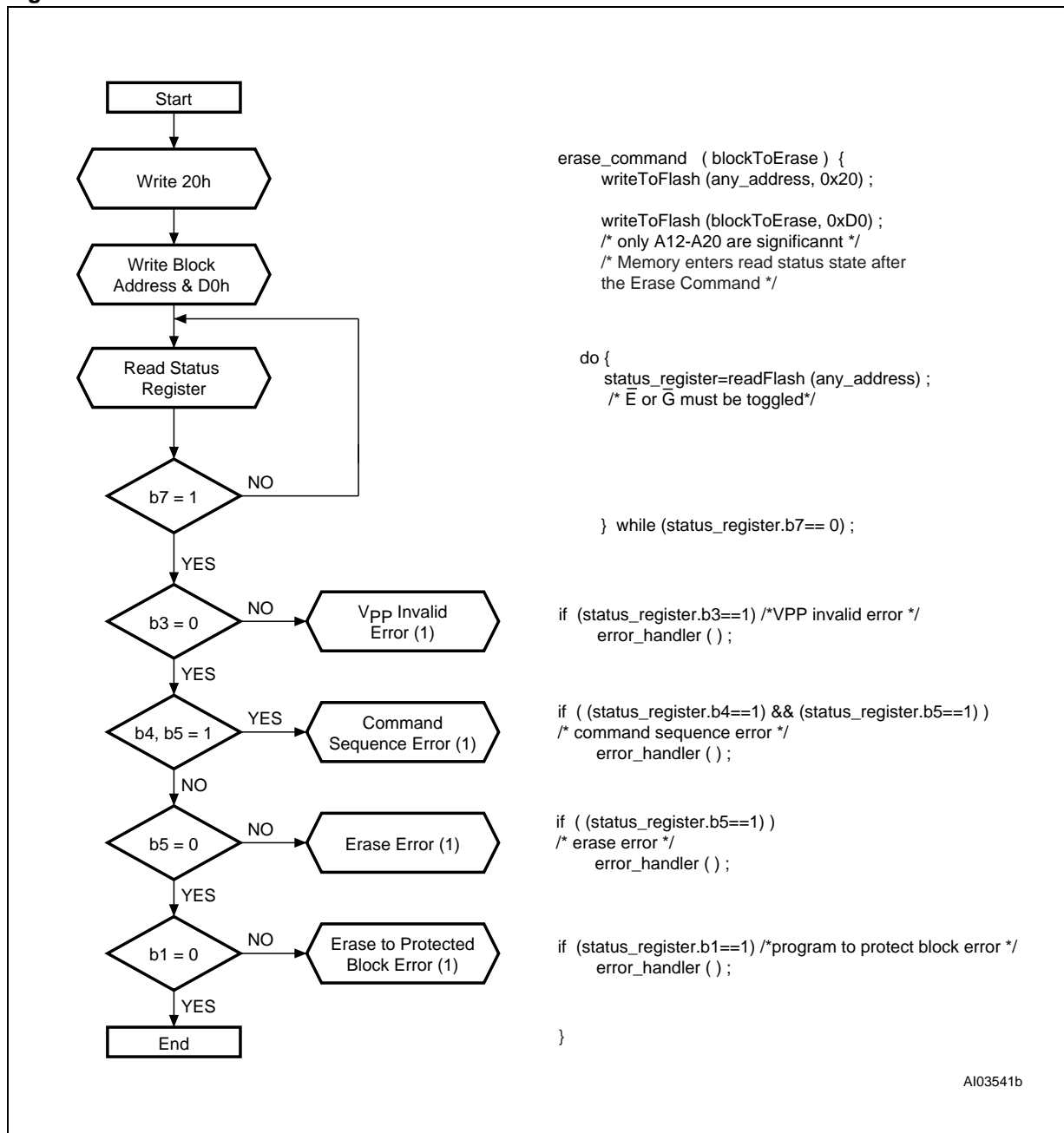
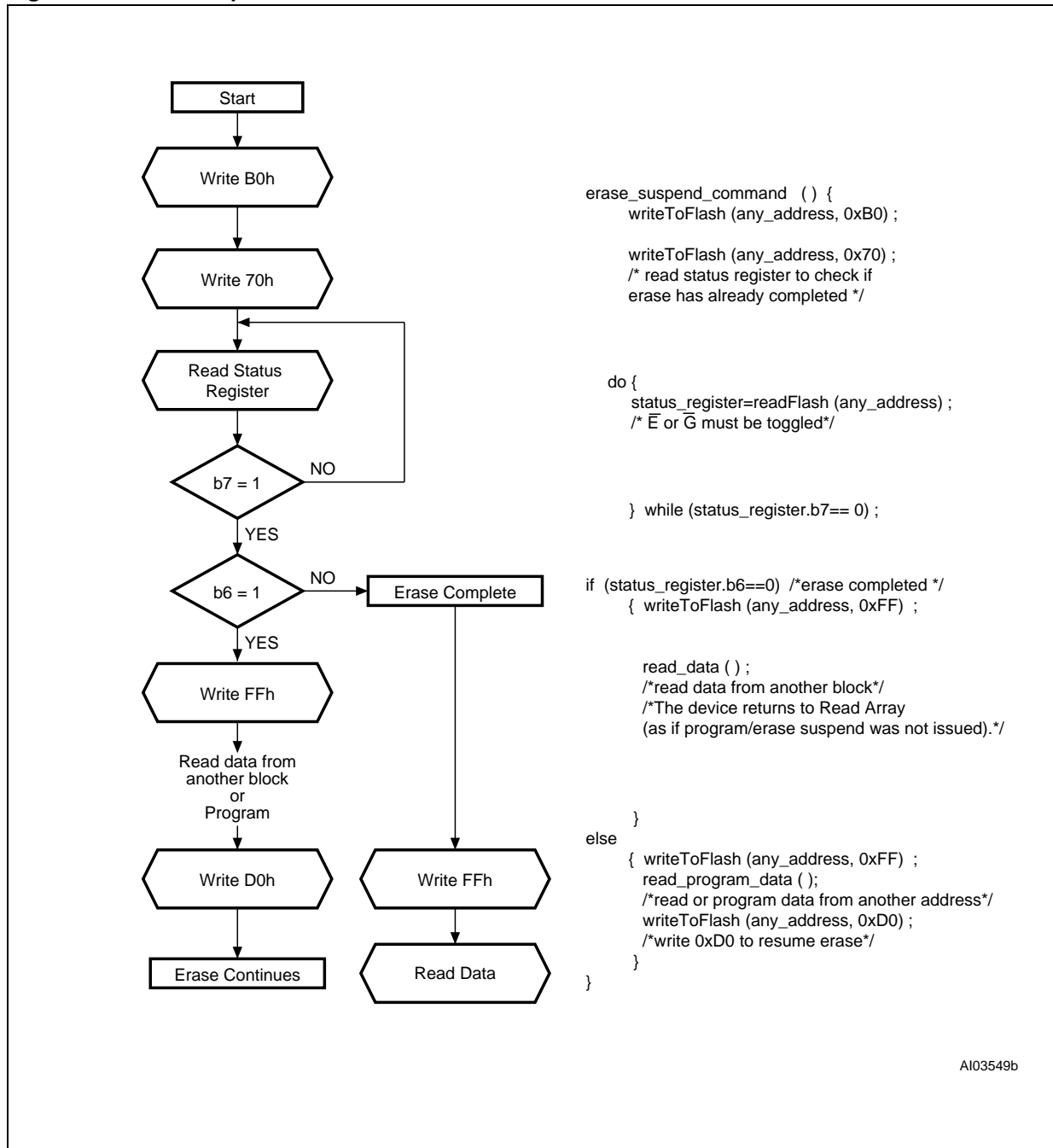

Figure 23. Erase Flowchart and Pseudo Code



Note: If an error is found, the Status Register must be cleared before further Program/Erase operations.

Figure 24. Erase Suspend & Resume Flowchart and Pseudo Code



APPENDIX D. COMMAND INTERFACE AND PROGRAM/ERASE CONTROLLER STATE

Table 30. Write State Machine Current/Next

Current State	SR bit 7	Data When Read	Command Input (and Next State)									
			Read Array (FFh)	Program Setup (10/40h)	Erase Setup (20h)	Erase Confirm (D0h)	Program/ Erase Suspend (B0h)	Program/ Erase Resume (D0h)	Read Status (70h)	Clear Status (50h)	Read Elect.Sg. (90h)	
Read Array	"1"	Array	Read Array	Program Setup	Erase Setup	Read Array			Read Status	Read Array	Read Elect.Sg.	
Read Status	"1"	Status	Read Array	Program Setup	Erase Setup	Read Array			Read Status	Read Array	Read Elect.Sg.	
Read Elect.Sg.	"1"	Electronic Signature	Read Array	Program Setup	Erase Setup	Read Array			Read Status	Read Array	Read Elect.Sg.	
Program Setup	"1"	Status	Program (Command input = Data to be Programmed)									
Program (continue)	"0"	Status	Program (continue)			Program Suspend to Read Status	Program (continue)					
Program Suspend to Read Status	"1"	Status	Program Suspend to Read Array	Program Suspend to Read Array		Program (continue)	Program Suspend to Read Array	Program (continue)	Program Suspend to Read Status	Program Suspend to Read Array	Program Suspend to Read Elect.Sg.	
Program Suspend to Read Array	"1"	Array	Program Suspend to Read Array	Program Suspend to Read Array		Program (continue)	Program Suspend to Read Array	Program (continue)	Program Suspend to Read Status	Program Suspend to Read Array	Program Suspend to Read Elect.Sg.	
Program Suspend to Read Elect.Sg.	"1"	Electronic Signature	Program Suspend to Read Array	Program Suspend to Read Array		Program (continue)	Program Suspend to Read Array	Program (continue)	Program Suspend to Read Status	Program Suspend to Read Array	Program Suspend to Read Elect.Sg.	
Program (complete)	"1"	Status	Read Array	Program Setup	Erase Setup	Read Array			Read Status	Read Array	Read Elect.Sg.	
Erase Setup	"1"	Status	Erase Command Error			Erase (continue)	Erase Command Error	Erase (continue)	Erase Command Error			
Erase Cmd. Error	"0"	Status	Read Array	Program Setup	Erase Setup	Read Array			Read Status	Read Array	Read Elect.Sg.	
Erase (continue)	"1"	Status	Erase (continue)				Erase Suspend to Read Status	Erase (continue)				
Erase Suspend to Read Status	"1"	Status	Erase Suspend to Read Array	Program Setup	Erase Suspend to Read Array	Erase (continue)	Erase Suspend to Read Array	Erase (continue)	Erase Suspend to Read Status	Erase Suspend to Read Array	Erase Suspend to Read Elect.Sg.	
Erase Suspend to Read Array	"1"	Array	Erase Suspend to Read Array	Program Setup	Erase Suspend to Read Array	Erase (continue)	Erase Suspend to Read Array	Erase (continue)	Erase Suspend to Read Status	Erase Suspend to Read Array	Erase Suspend to Read Elect.Sg.	
Erase Suspend to Read Elect.Sg.	"1"	Electronic Signature	Erase Suspend to Read Array	Program Setup	Erase Suspend to Read Array	Erase (continue)	Erase Suspend to Read Array	Erase (continue)	Erase Suspend to Read Status	Erase Suspend to Read Array	Erase Suspend to Read Elect.Sg.	
Erase (complete)	"1"	Status	Read Array	Program Setup	Erase Setup	Read Array			Read Status	Read Array	Read Elect.Sg.	

Note: Elect.Sg. = Electronic Signature.



Information furnished is believed to be accurate and reliable. However, STMicroelectronics assumes no responsibility for the consequences of use of such information nor for any infringement of patents or other rights of third parties which may result from its use. No license is granted by implication or otherwise under any patent or patent rights of STMicroelectronics. Specifications mentioned in this publication are subject to change without notice. This publication supersedes and replaces all information previously supplied. STMicroelectronics products are not authorized for use as critical components in life support devices or systems without express written approval of STMicroelectronics.

The ST logo is registered trademark of STMicroelectronics  
All other names are the property of their respective owners.

© 2002 STMicroelectronics - All Rights Reserved

STMicroelectronics GROUP OF COMPANIES

Australia - Brazil - Canada - China - Finland - France - Germany - Hong Kong - India - Israel - Italy - Japan - Malaysia - Malta -  
Morocco - Singapore - Spain - Sweden - Switzerland - United Kingdom - United States

[www.st.com](http://www.st.com)